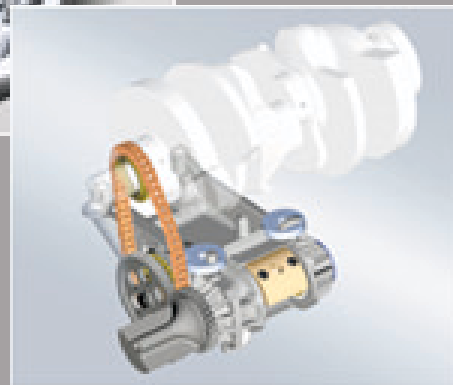


Service.



The 2.0 I R4 and
the 3.0 I V6 engines

Self-study programme 255



| | Page |
|---|------|
| The 2.0 I-5V engine | |
| Overview – Technical data | 4 |
| Balancer shaft module | 6 |
| New cylinder head | 7 |
| Map-controlled cooling | 10 |
| Functional diagram for the 2.0 I-5V | 12 |
| The 3.0 I-5V engine | |
| Overview – Technical data | 14 |
| Crankcase | 15 |
| Balancer shaft | 17 |
| Oil circuit | 18 |
| Cylinder head | 20 |
| Air intake | 27 |
| Vacuum system overview | 29 |
| Exhaust system | 32 |
| Engine management | 33 |
| Sensors/Actuators | 33 |
| System overview | 34 |
| Functional diagram for the 3.0 I-5V | 36 |

The self-study programme will provide you with information on design and functions.

The self-study programme is not intended as a workshop manual.

For maintenance and repair work it is essential that you refer to the current technical literature.

New



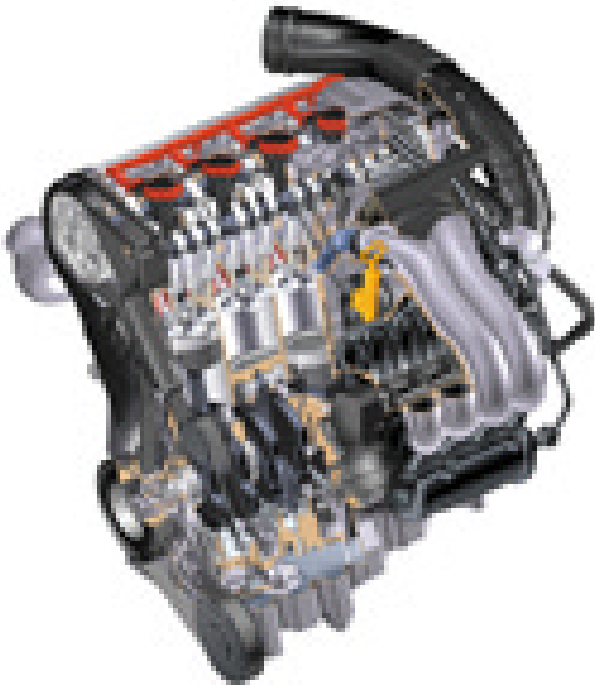
**Important:
Note**



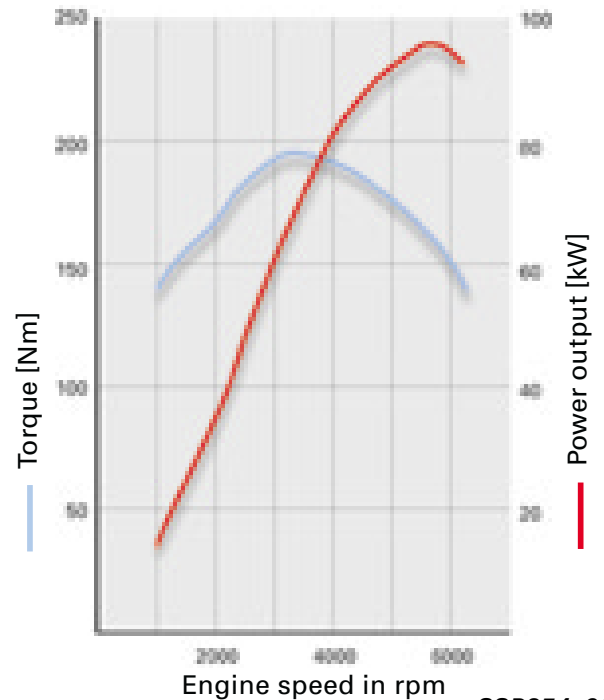
Overview



The 2.0 I-5V engine



SSP254_038



SSP254_060

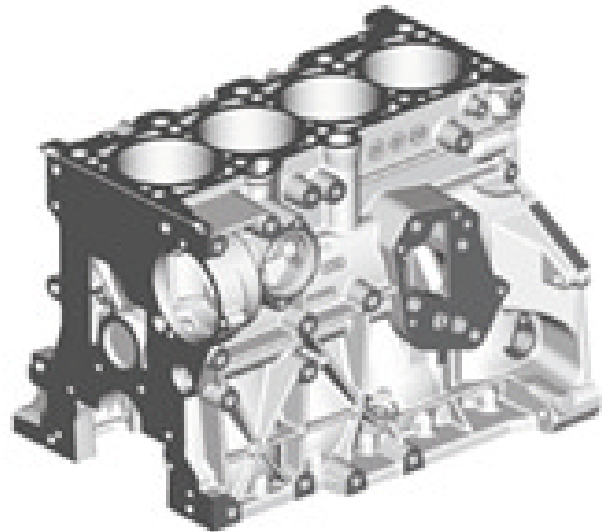
Technical data

| | | | |
|---------------|---|----------------------------------|---|
| Engine code: | ALT | Adjustment range Inlet camshaft: | 42° CA (Crank Angle) |
| Capacity: | 1984 cm ³ | Engine management: | ME 7.5 |
| Bore: | 82.5 mm | Exhaust emissions class: | EU 4 |
| Stroke: | 92.8 mm | Capacities: | Engine oil (incl. filter) 4.2 l |
| Compression: | 10.3 : 1 | Consumption: | urban 11.4 l/100 km non-urban 5.9 l/100 km average 7.9 l/100 km |
| Power output: | 96 kW (130 PS) | Acceleration from 0 to 100 km/h: | 9.9 s |
| Torque: | 195 Nm at 3300 rpm | Fuel: | 4-star petrol, unleaded, 95 (91) RON |
| Valve timing: | bucket tappets with hydraulic valve lifters | Weight: | 129 kg |
| Valves: | 5 per cylinder | | |
| Valve timing: | inlet opens 26° CA after TDC inlet closes 48° CA after BDC exhaust opens 32° CA before BDC exhaust closes 8° CA before TDC | | |

Engine block

The engine block is made of aluminium alloy and, with a cylinder spacing of 88 mm and a length of only 460 mm, is the most compact unit in its class.

For reasons of rigidity, the aluminium crankcase is designed as a "closed deck" construction.



"open deck" means that the cylinder liners are installed with only small cast connections to the block.

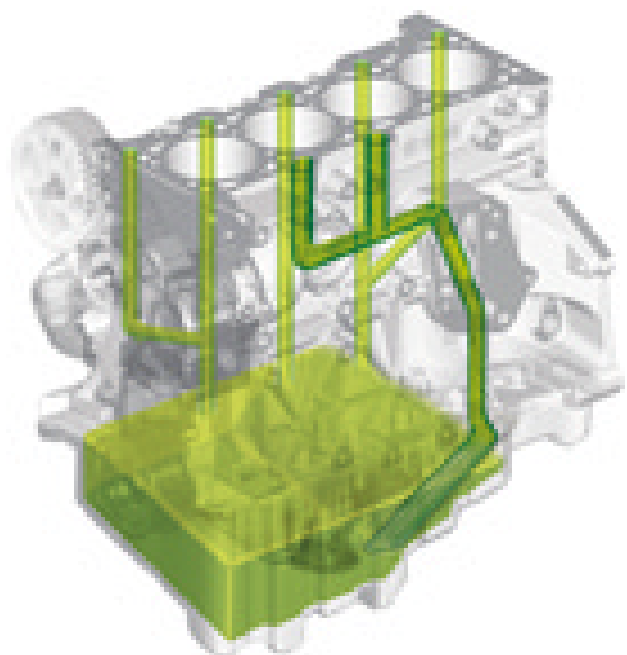
"closed deck" means that the cylinder linings are cast in one piece with the block.

SSP255_004

In order to ensure sufficient cooling between the cylinder liners, cooling ribs of 0.8 mm in width are provided.

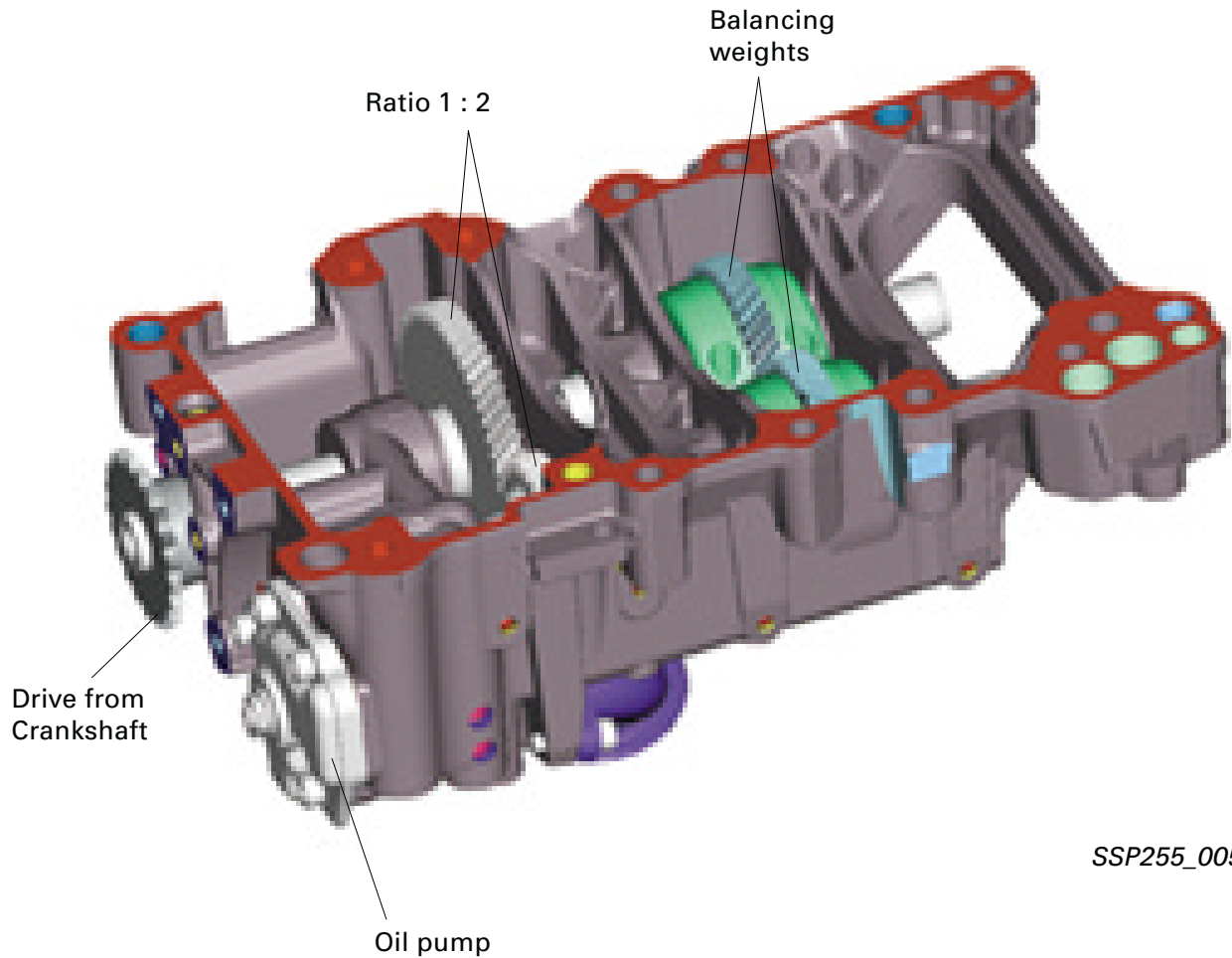
The oil return ducts on the inlet side are arranged such that the oil (dark green) is guided to the sump via a collection channel from the cylinder head through an inlet pipe below the oil level.

On the exhaust side, the oil (light green) runs down the crankcase wall due to the angle of the engine in the installation position.



SSP255_053

Balancer shaft module



SSP255_005

This module is intended to compensate the inertia forces that occur and hence reduce drive unit vibration.

To further improve running smoothness of the 4-cylinder engine, two counter-rotating balancer shafts rotating at double crankshaft speed are integrated in an oil pump/balancer shaft module.

The drive chain sprocket on the balancer shaft unit is driven via a three-point chain drive (crankshaft/balancer shaft/oil pump).

The initial ratio of the crankshaft to the drive shaft on the balancer shaft module is 1 : 1. The stepping up to double crankshaft speed takes place in the 1st drive stage via a helical gear pair.

The balancing weights are integrated into the gears of the 2nd stage. Here, the rotational direction of the second balancer shaft is reversed.

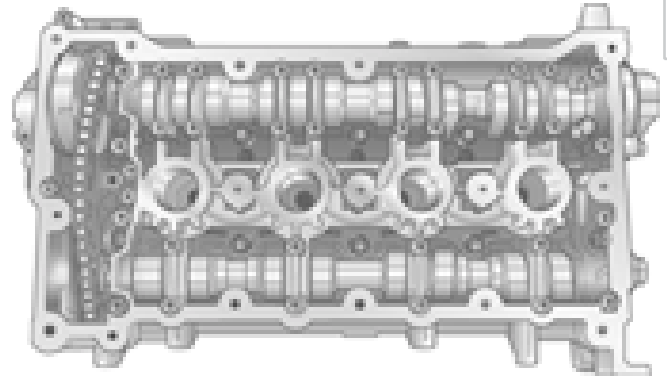
The second degree inertia forces are 100 % compensated.

New cylinder head

The cylinder head is designed as a ladder-type frame for better rigidity and optimum acoustics (see diagram SSP255_018 on page 20).

This means that the camshafts are installed in the cylinder head with greater bending resistance. Individual bearingcaps are not required.

The exhaustcamshaft is driven by the toothed belt. The inlet camshaft is driven by a roller chain from the exhaust camshaft. The roller chain is tensioned via a hydraulic chain tensioner.

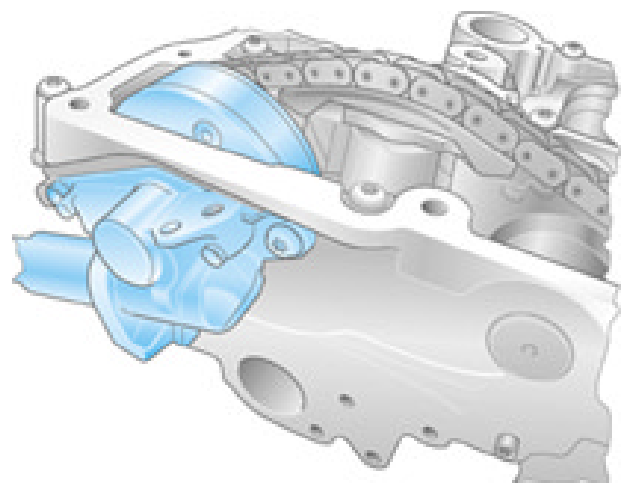


SSP255_006



However, the hydraulic chain tensioner is not responsible for the camshaft timing control.

The inlet camshaft is continuously adjusted by a hydraulic swivelling motor. In order to achieve optimum torque characteristics, the inlet camshaft can be map-adjusted by a crank angle of up to 42°.



SSP255_007



The camshaft timing control function is described for the 3.0 I-V6-5V engine.

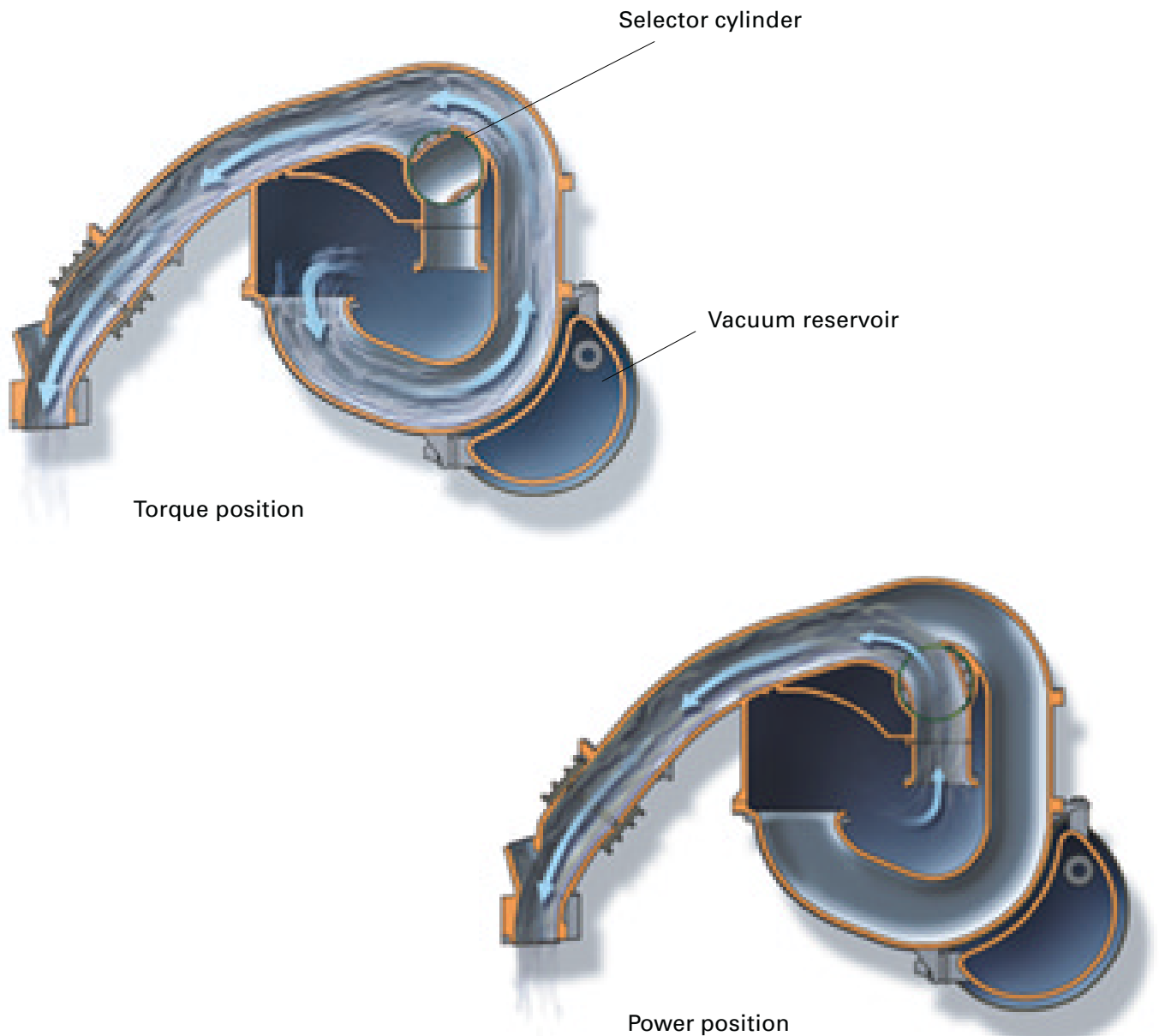
Engine

Inlet manifold changeover system



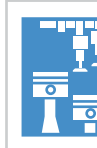
The power and torque characteristics are realised with the aid of a two-stage inlet manifold changeover system, whereby the changeover point from short to long intake path occurs between 2000-3700 rpm at 65 % load.

The intake path is selected via a selector cylinder which separates the individual intake ducts via elastic sealing rings and strips. The switch between torque and power positions is electro-pneumatic (load/torque/temperature dependent).



SSP255_008

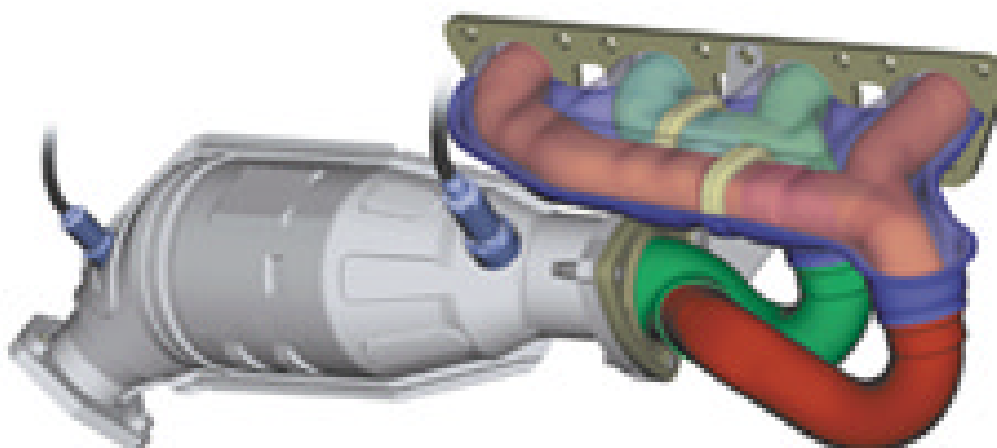
| | | |
|--|--|--|
| | | |
|--|--|--|



Exhaust emissions control

A staged metal catalytic converter is installed close to the engine to allow it to reach operating temperature rapidly after the engine has been started.

A fast start is also facilitated by the exhaust manifold which is manufactured in an internal high pressure moulding process (IHM) and has very low heat capacity. As a result, it absorbs less heat energy.



SSP255_009

The staged catalytic converter is divided into two different metal parts, with a cell density of 400 cpsi and a length of 50.8 mm in the first stage and a cell density of 500 cpsi and a length of 110 mm in the second stage.

! For more information on the internal high pressure moulding process, please see SSP 239 – Audi A2, Body.

Vacuum system

Constantly increasing load requirements (wider opened throttle valve) in some operating statuses, e.g. when the catalytic converter is warming up while the engine is idling after starting up, result in a reduction of the vacuum generated by the engine. To avoid losing any braking efficiency, an electric vacuum pump is used to assist braking in vehicles with automatic gearbox.

! For further explanations, please see the 3.0 I-V6 engine on page 30.

Map-controlled cooling

The 2.0 l engine is equipped with map-controlled coolant temperature control. Compared to conventional thermostat-based systems, this improves the thermodynamic efficiency of the engine while also optimising torque.

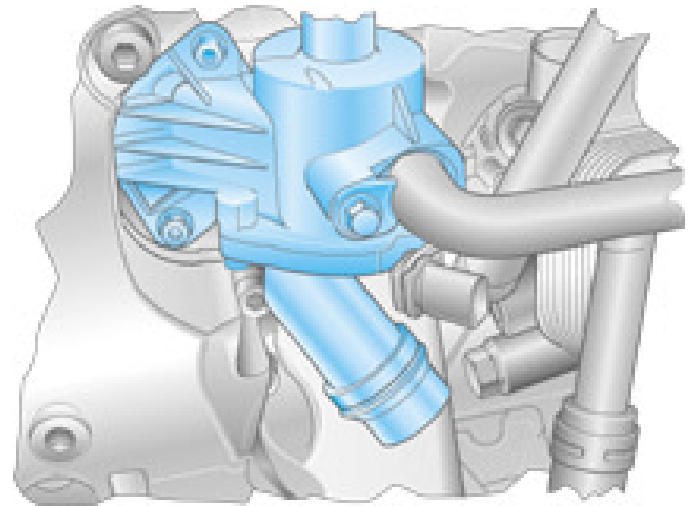
Thermostat-controlled systems work according to the on/off principle. This means: when the coolant reaches a temperature of approx. 100 °C, the wax-filled thermostat activates the large coolant circuit independently of engine load status. This setting is also the standard setting for all loads, except full throttle.

At full throttle, current is applied to a thermal pellet in the expanding element and heats up the wax, thereby opening the thermostat wider.

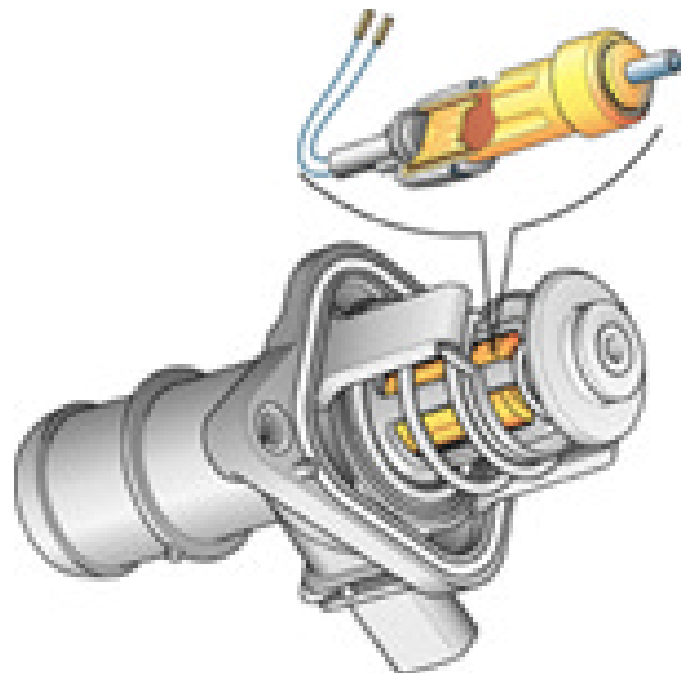
This reduces the coolant inlet temperature to 75 – 80 °C.

A high coolant temperature of approx. 100 – 105 °C improves thermodynamic efficiency and minimises the friction caused to the engine by the increasing oil temperature. Reducing coolant temperature at full throttle makes the combustion chambers cooler.

Cooler combustion chambers allow an earlier ignition point and so provide the desired gain in torque.



SSP255_010



SSP255_011



For more information, please see SSP 222, 1.6 l engine.

Notes

Engine







Functional diagram for the 2.0 I-5V



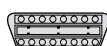
| | |
|------|---|
| F | Brake light switch |
| F36 | Clutch pedal switch |
| F47 | Brake pedal switch for cruise control system |
| F265 | Thermostat for map-controlled engine cooling |
| G2 | Coolant temperature sender |
| G6 | Fuel pump |
| G28 | Engine speed sender |
| G39 | Lambda probe |
| G40 | Hall sender |
| G42 | Intake air temperature sender |
| G61 | Knock sensor 1 |
| G62 | Coolant temperature sender |
| G66 | Knock sensor 2 |
| G70 | Air mass meter |
| G79 | Accelerator position sender |
| G82 | Coolant temperature sender for engine outlet |
| G130 | Lambda probe downstream of catalytic converter |
| G185 | Accelerator position sender 2 |
| G186 | Throttle valve drive (electronic throttle control) |
| G187 | Angle sender 1 for throttle valve drive (electronic throttle control) |
| G188 | Angle sender 2 for throttle valve drive (electronic throttle control) |
| G294 | Pressure sensor for brake servo |
| J17 | Fuel pump relay |
| J138 | Control unit for radiator fan run-on |
| J271 | Power supply relay for Motronic |
| J299 | Secondary air pump relay |
| J569 | Brake servo relay |
| M | Lamp |
| N | Ignition coil |
| N30 | Injector, cylinder 1 |
| N31 | Injector, cylinder 2 |
| N32 | Injector, cylinder 3 |
| N33 | Injector, cylinder 4 |
| N80 | Solenoid valve 1 for activated charcoal filter system |
| N128 | Ignition coil 2 |
| N158 | Ignition coil 3 |
| N163 | Ignition coil 4 |
| N205 | Valve 1 for camshaft timing control |
| N239 | Intake manifold flap changeover valve |

| | |
|------|--|
| S | Fuses |
| V101 | Motor for secondary air pump |
| V192 | Vacuum pump for brake |
| Z19 | Heater for lambda probe |
| Z29 | Heater for lambda probe 1, downstream of catalytic converter |

Colour coding

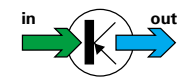
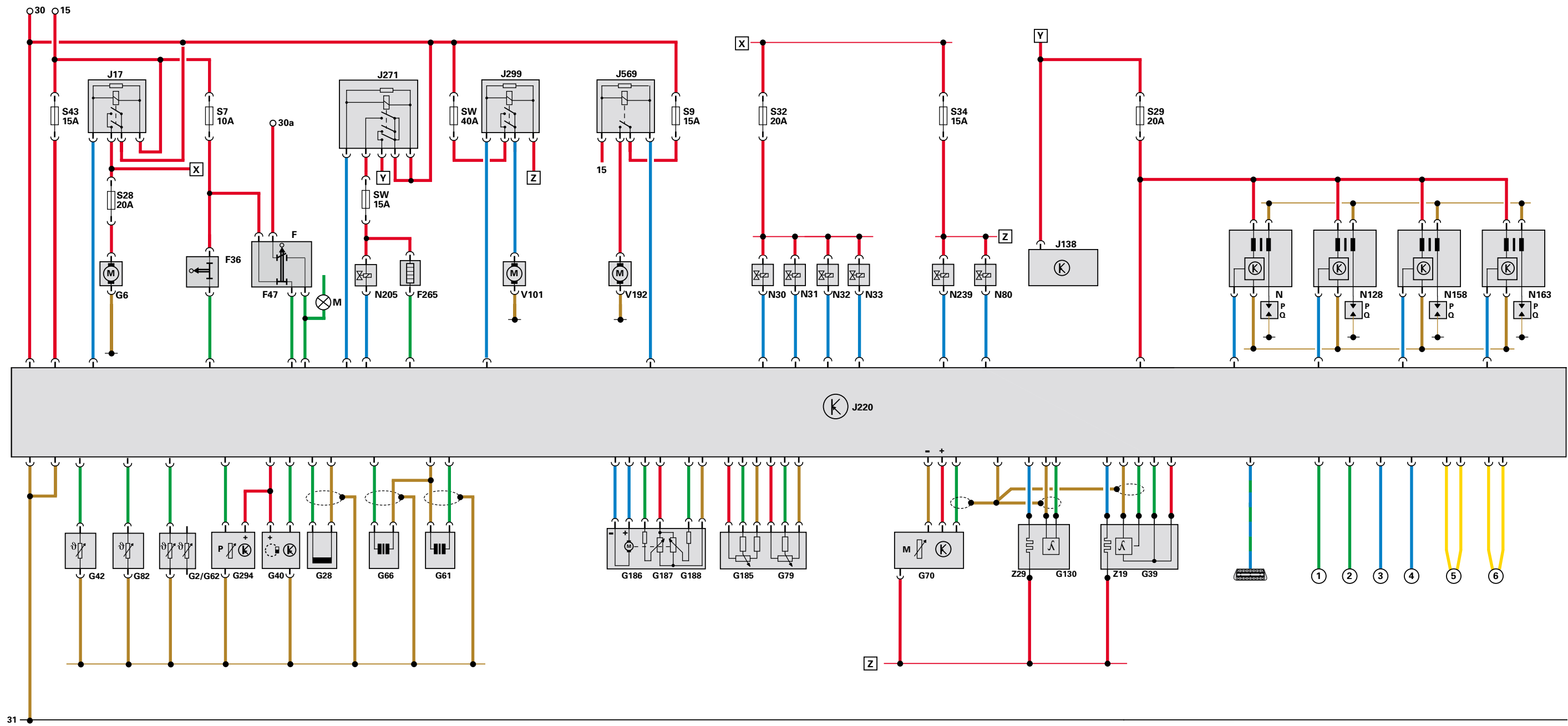
| | |
|---|-------------------------|
|  | = Input signal |
|  | = Output signal |
|  | = Positive power supply |
|  | = Earth |
|  | = CAN BUS |
|  | = Bi-directional |

Auxiliary signals



K diagnostic connection

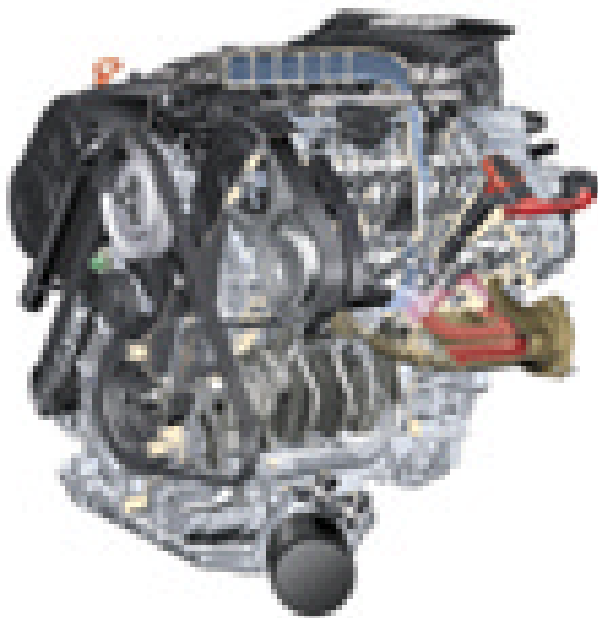
- ① Crash signal
- ② Cruise Control System ON/OFF
- ③ PWM signal to radiator fan
- ④ TD signal (V30 automatic gearbox only)
- ⑤ Databus drive
- ⑥ Databus information
- X } Connection within the functional diagram
- Y }
- Z }



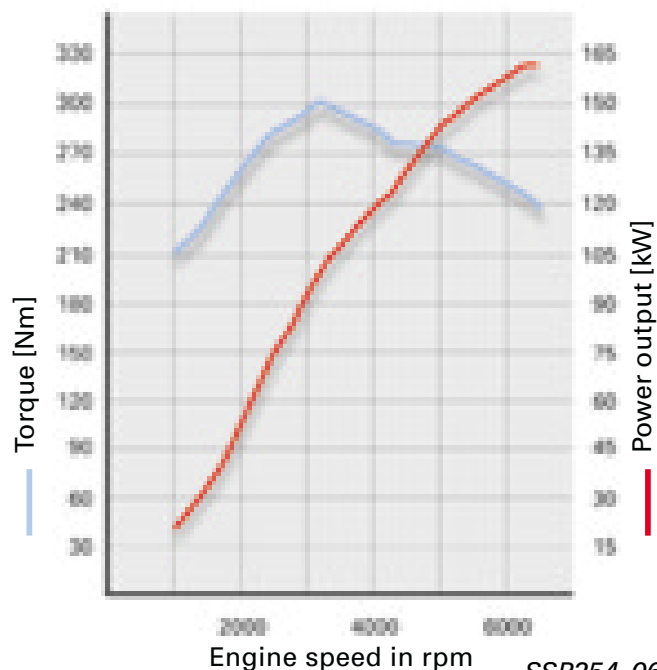
Overview



The 3.0 I-5V engine



SSP254_030



SSP254_061

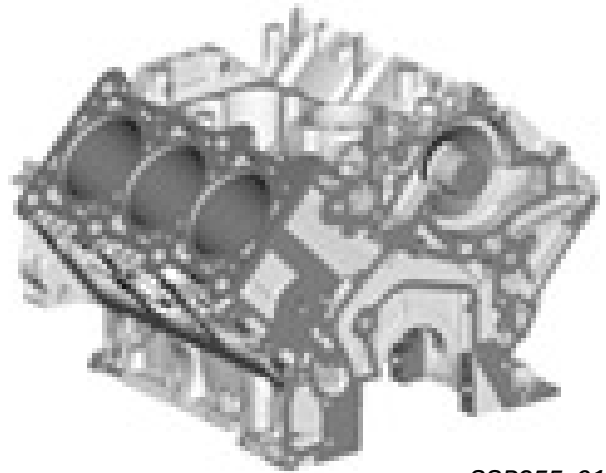
Technical data

| | | | |
|---------------|--|----------------------------------|---|
| Engine code: | ASN | Engine management: | ME 7.1.1 |
| Capacity: | 2976 cm ³ | Exhaust emissions class: | EU 4 |
| Bore: | 82.5 mm | Capacities: | Engine oil (incl. filter) 6.3 l |
| Stroke: | 92.8 mm | Consumption: | urban 13.7 l/100 km non-urban 7.1 l/100 km average 9.5 l/100 km |
| Compression: | 10.5 : 1 | Acceleration from 0 to 100 km/h: | 6.9 s |
| Power output: | 162 kW (220 PS) | Fuel: | Super Plus unleaded 98 (95) RON |
| Torque: | 300 Nm at 3200 rpm | Weight: | 165 kg |
| Valve timing: | bucket tappets with hydraulic valve lifters | | |
| Valves: | 5 per cylinder | | |
| Valve timing: | inlet opens 20° CA after TDC inlet closes 50° CA after BDC exhaust opens 47° CA before BDC exhaust closes 17° CA before TDC | | |

Crankcase

In terms of lower weight, higher output and higher maximum engine speed, all the experience gained with V8 aluminium crankcases points to only one type of aluminium crankcase, offering the best characteristics in relation to strength, durability and oil system optimisation.

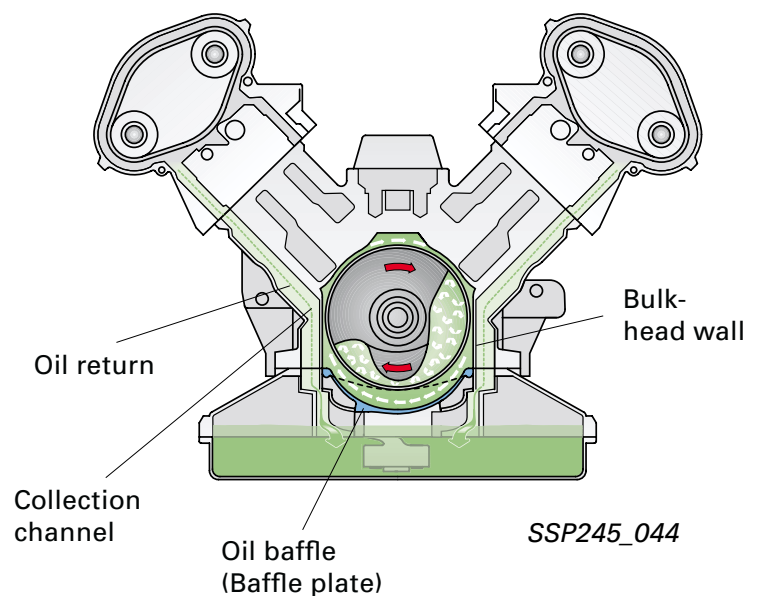
The aluminium crankcase with cast iron cylinder liners is manufactured using the Cosworth casting process.



SSP255_012

The oil returning from the cylinder heads is guided along the bulkhead walls and through the oil baffle plate below the dynamic oil level into the sump.

This considerably reduces the gas content of the oil caused by the crank drive.



SSP245_044

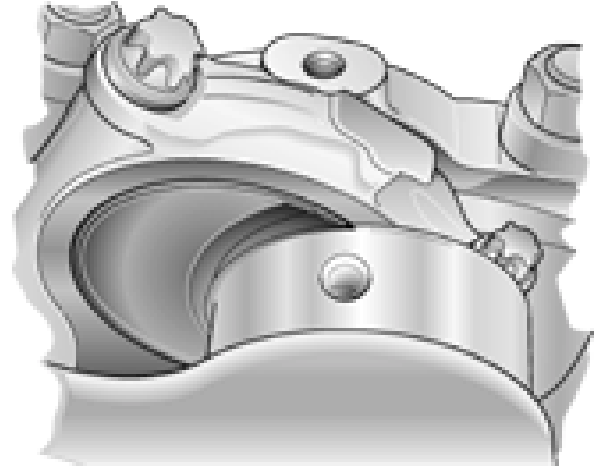


Engine

Crank assembly



The crankshaft is mounted on 4 bearings with split crank pins (30° offset), allowing a uniform firing sequence of 120°.

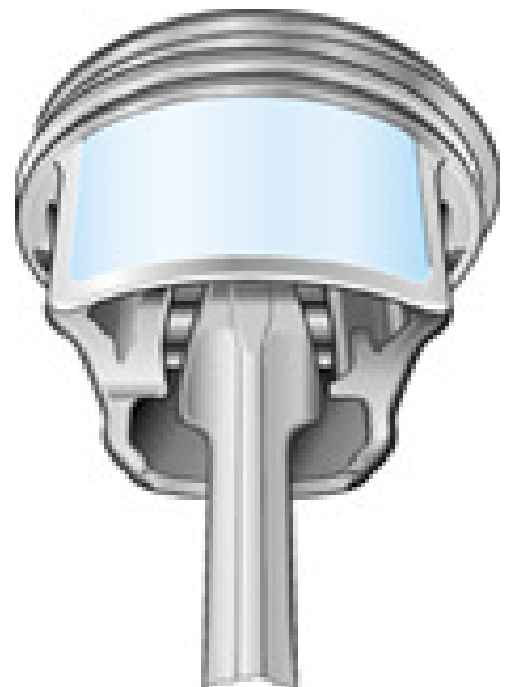


SSP255_013

Lightweight smooth shaft pistons with a curved box form and closely arranged piston pin eyes have been adapted to the trapezoidal conrod.

The piston pins are shorter and have a smaller diameter, allowing a reduction in the weight of the masses moving back and forth (oscillating).

The pistons are cooled by oil spray nozzles in the crankcase. The piston shaft has a wear-resistant ferroprint running surface which is produced by a screen printing process.



SSP255_014

Balancer shaft

The free inertia forces in V6 engines can be completely compensated with a cylinder angle of 90°.

The free moments of inertia (1st degree) cannot be completely eliminated without additional measures and some comfort is lost.

To keep up with growing comfort requirements, a balancer shaft has been installed below the crankcase.

The oil pump and the balancer shaft are combined into a single aluminium module. The shaft is positioned on plain bearing shells and is supplied with oil from the rear fixed bearing.

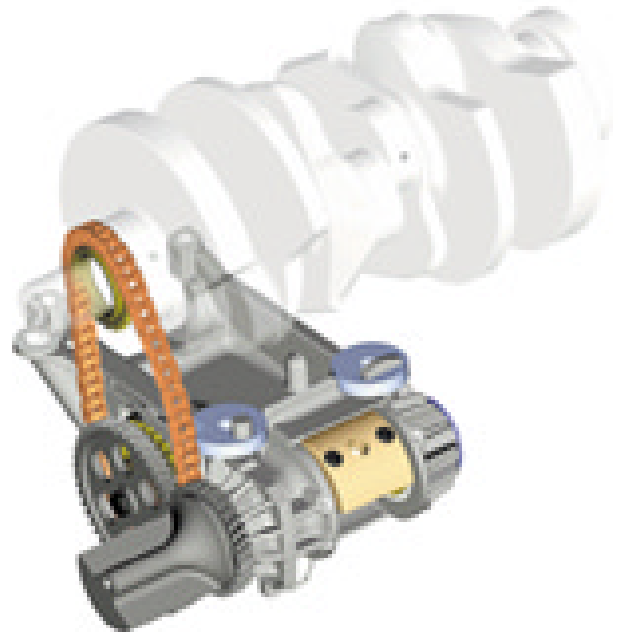
The front free bearing is lubricated via a bore in the shaft.

Drive is provided by a roller chain from the crankshaft to the oil pump shaft.

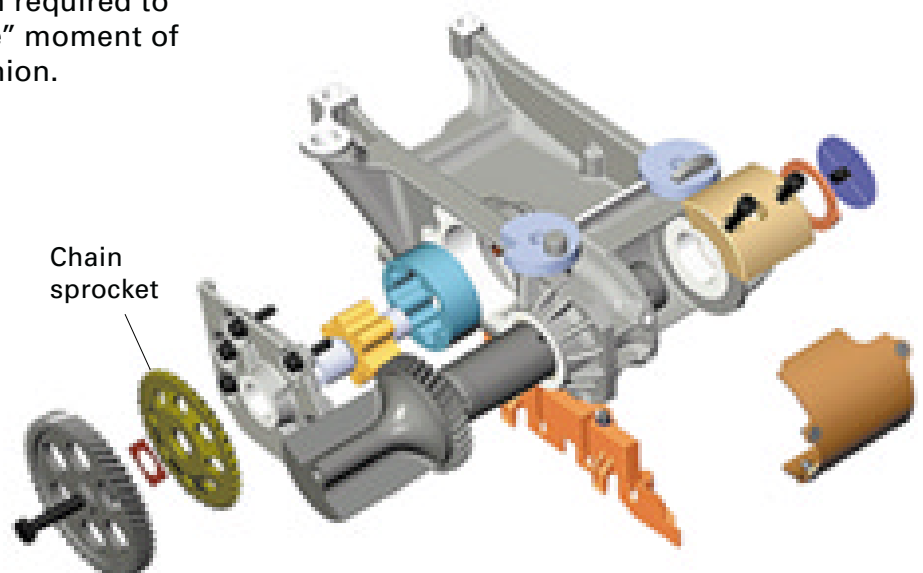
The gear driving the balancer shaft is mounted in front of the chain sprocket, and meshes with the gear on the balancer shaft with a transmission ratio of 1 : 1.

Thus the balancer shaft runs counter to the direction of engine rotation.

The reversal of rotation direction required to compensate for the "first degree" moment of inertia is realised by the spur pinion.



SSP255_015

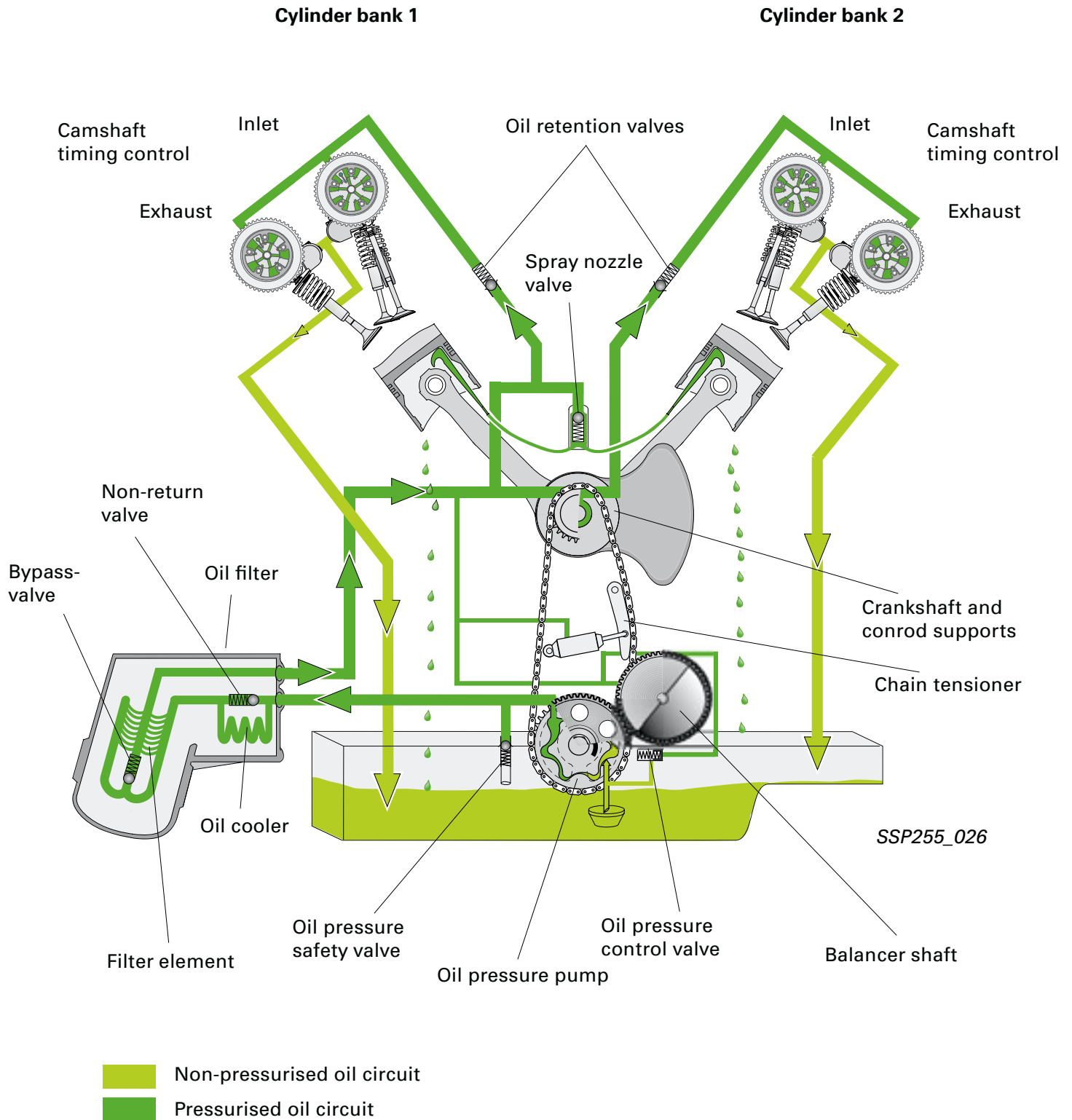


SSP255_016

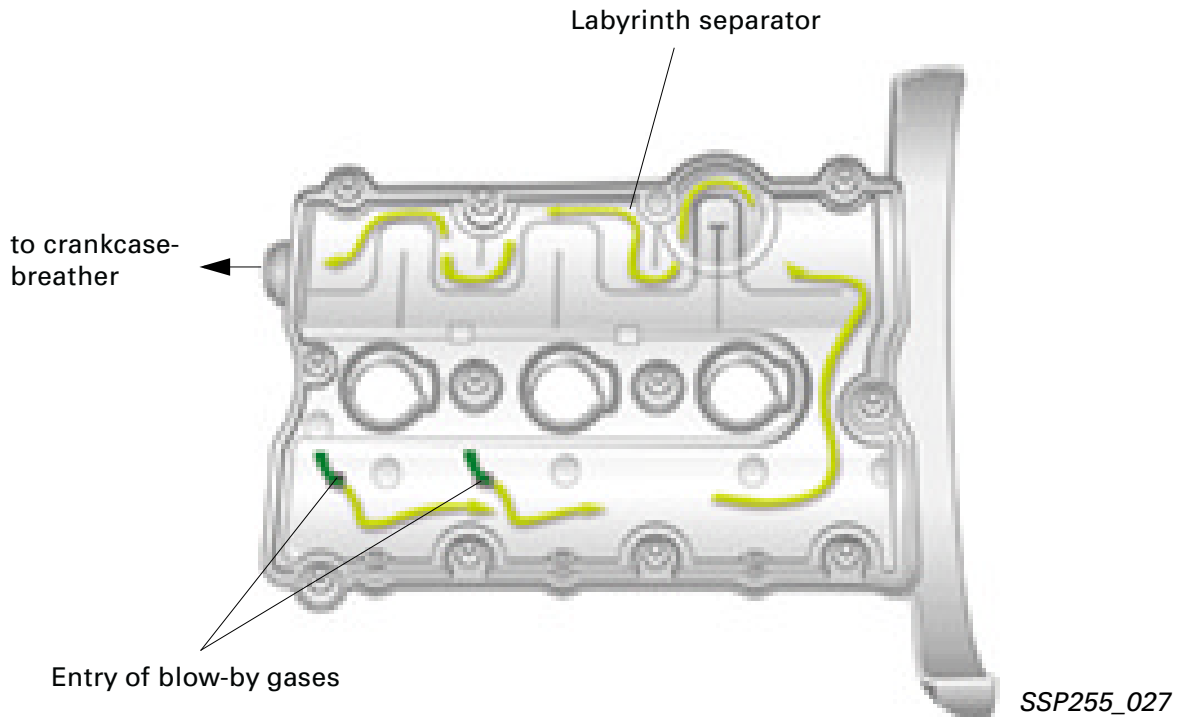
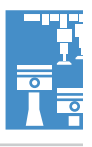


Engine

Oil circuit



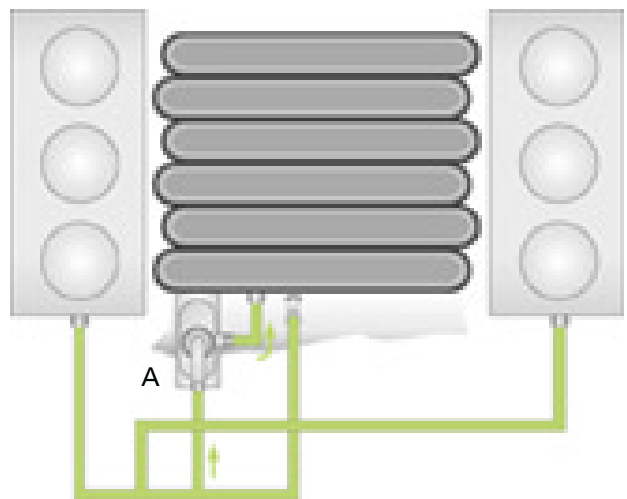
Crankcase ventilation



Similarly to the current V6 engines, the oil from the V-chamber cover and the two cylinder head covers is fed into the oil circuit and vented via the integrated labyrinth separator.

The blow-by gases for combustion are introduced directly into the intake manifold and not upstream of the throttle valve.

A differential pressure controlled diaphragm valve regulates the required vacuum level for the crankcase.



A differential pressure controlled diaphragm valve

Engine

Cylinder head


For reasons concerning rigidity and acoustics, the camshaft supports have been changed from single bearing caps to a one-piece pressure-cast aluminium ladder-type frame.

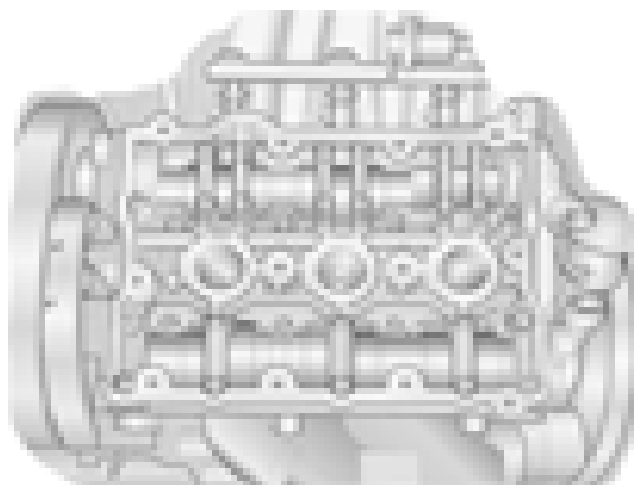
The front faces and the bearings for the ladder-type frame are machined after assembly. This means that plane sealing surfaces between cylinder head cover and ladder frame and the attached module housings are designed as axial sealing surfaces.

The cylinder head features a Tumble inlet duct (bi-turbo) in order to achieve a high internal exhaust gas recirculation rate even in the low rpm and load range.

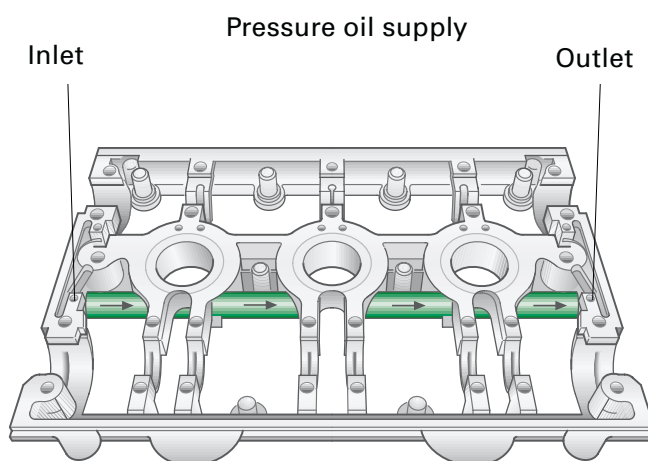
The cylinder head cover with a welded bulkhead provides better acoustics and a more rigid connection. This bulkhead with integrated labyrinth separators is used as a cover for the extended ventilation area and as an additional oil separator for the vent gases. The oil separator volume has been increased.

Thanks to the ladder frame design, the pressure oil required for continuous camshaft timing control is supplied by an oil supply unit bolted to the front face.

 The ladder frame has bores on both sides to supply pressure oil. This allows the cylinder head to be used on the left or right cylinder bank by rotating the cylinder head through 180°.

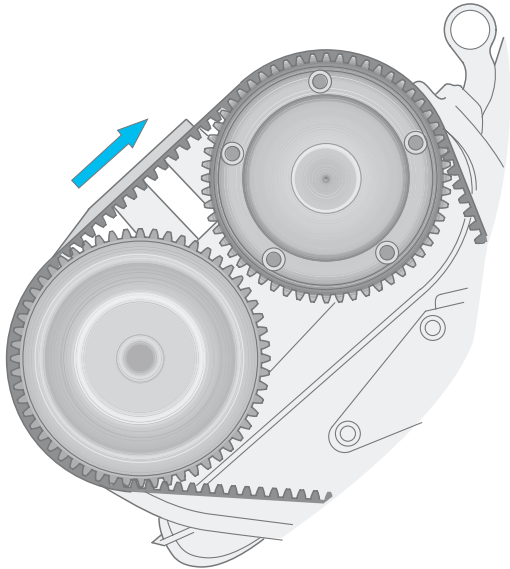


SSP255_017



SSP255_018

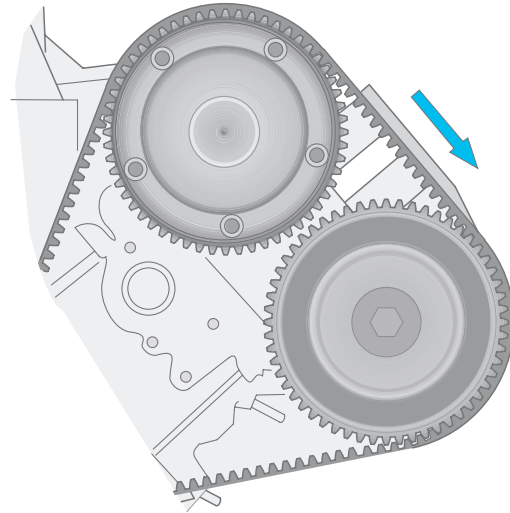
Cylinder bank 1



SSP255_050

Exhaust swivelling motor (with damper) Inlet swivelling motor

Cylinder bank 2



SSP255_051

Inlet swivelling motor Exhaust swivelling motor (without damper)

The central, low-throttle i.e. block-oil pressure driven oil supply was a prerequisite for the use of the oil pressure driven camshaft timing control.

The four camshafts are driven directly by the toothed belt.

Thermodynamic tests indicated an adjustment range of up to 42° crank angle on the inlet side and up to 22° on the exhaust side.

Adjustment is made by four hydraulic swivelling motors, and occurs on the

- inlet side continuously from 20° CA after TDC (retard) up to 22° CA before TDC (advance)
- and on the
- exhaust side with on/off controls (advance/retard).



The inlet swivelling motors of cylinder banks 1 and 2 are in the rest position (no pressure) in the retard position. The exhaust swivelling motors of cylinder banks 1 and 2 are in the rest position in the advance setting.

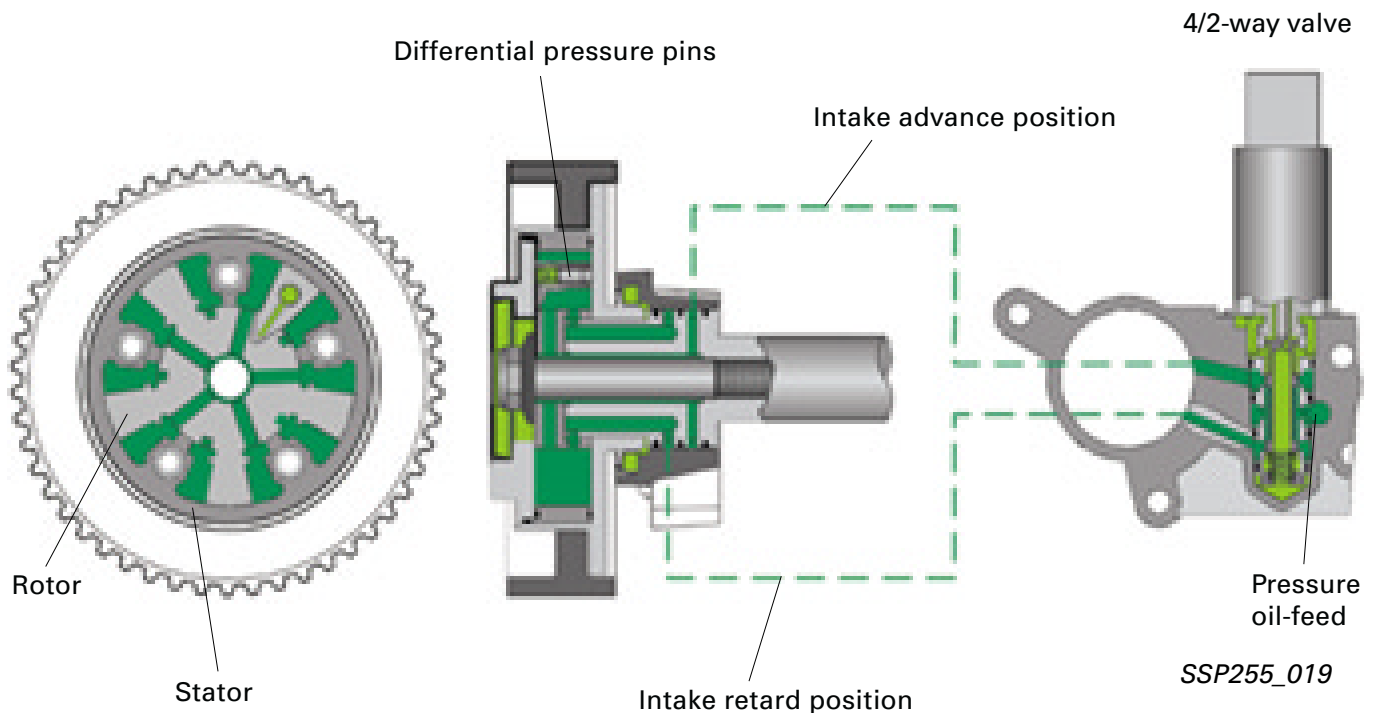


Engine

Continuous camshaft timing control

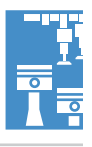


Figure shows standard setting:

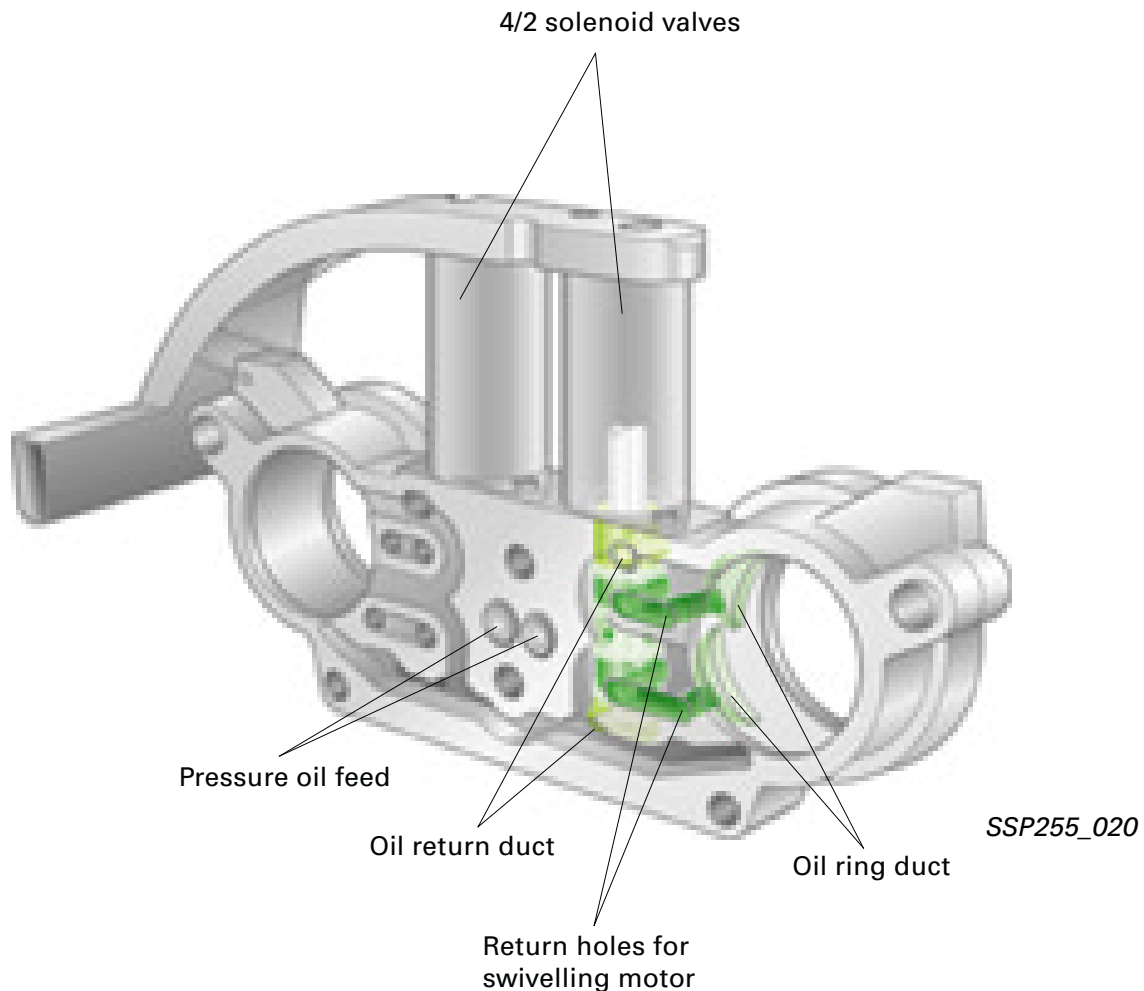


The swivelling motor adjusters are supplied by the engine oil pump via the pressure line in the cylinder head. Adjustment of the inlet camshafts is made by means of two pulse-width modulated 4/2 way proportional valves. In contrast, adjustment of the exhaust camshafts is made via two black-white 4/2 way solenoid valves. The solenoid valves are actuated by the engine control unit.

The maximum valve overlap is set at 1900 rpm to achieve the highest possible torque or to perform internal exhaust gas recirculation.



Oil supply module



The pressure oil required for adjustment is fed through the camshaft to the adjuster via an oil ring duct.

The inner ring (rotor) of the swivelling motor is connected to the camshaft.
The outer ring (stator) is connected securely to the toothed belt sprocket.
The camshaft is adjusted in relation to the crankshaft by filling the working area between rotor and stator with oil.

In order to move to each position (0 - 42°) between stops, the 4/2 way proportional valve is regulated by the engine control unit. Regulation depends on speed, load and coolant temperature.

Engine

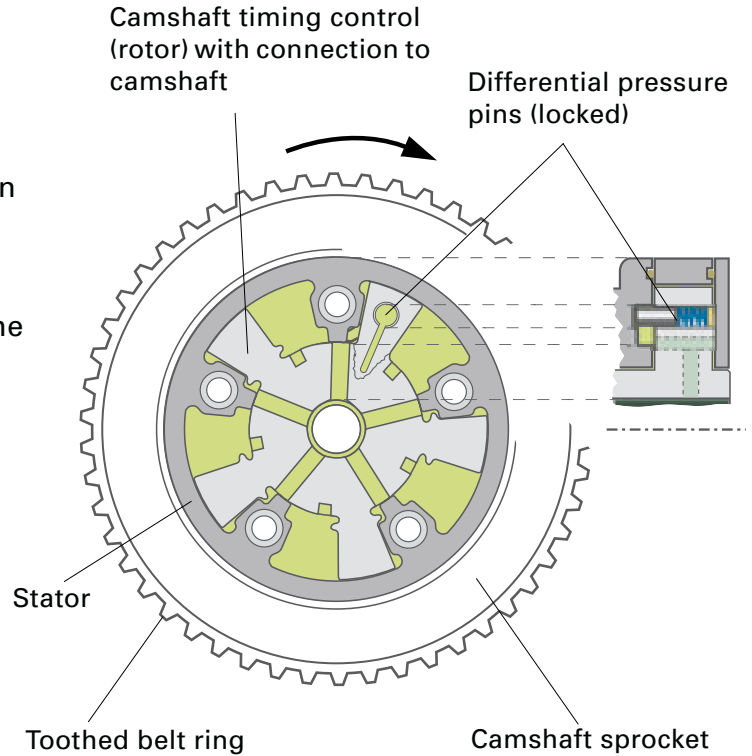
Inlet camshaft driving control (no pressure)

The 4/2 way valve has no power supply.

The spring-loaded differential pressure pin locks into a bore, thus preventing the camshaft from being adjusted during the start procedure.

It is locked into position by a selective return to the retard position when the engine is switched off.

The exhaust camshaft timing control is in the advance position.



SSP255_021

Inlet camshaft timing control in retard position (Engine running)

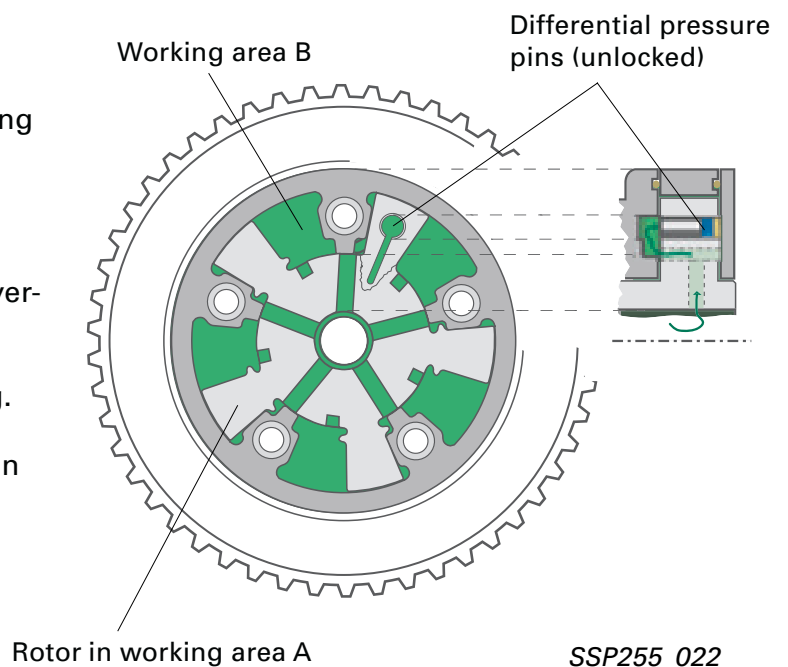
The springloaded differential pressure pin is unlocked by the engine oil pressure.

The solenoid valve opens the access to the working area B and holds the rotor in working area A.

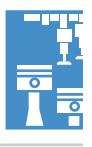
The inlet camshaft is in the retard position.

In the idling range, there is as little valve overlap as possible. This results in a low proportion of exhaust gas and therefore smooth and stable idling.

The exhaust camshaft is in advance position (solenoid valve off).



SSP255_022



Inlet camshaft in control position

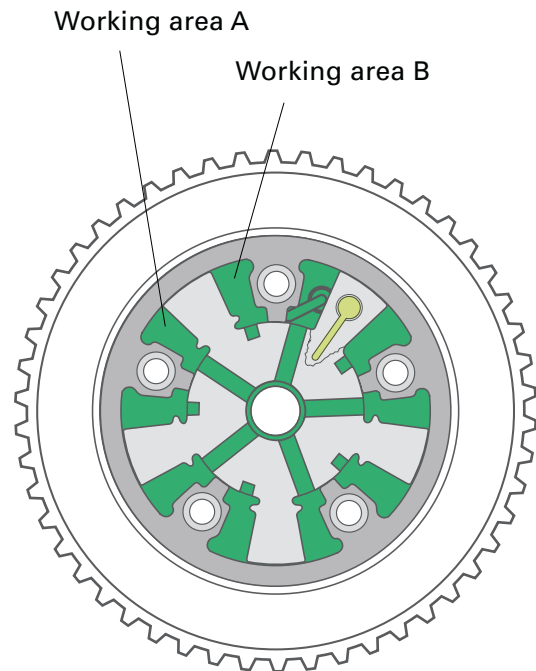
The solenoid valve is actuated by the engine control unit with a pulse-width modulated signal.

The solenoid valve piston is set such that both working areas are under oil pressure.

The rotor, and as a result the camshaft, moves in the direction of advance or retard in accordance with the oil pressure conditions in working areas A and B.

The pulse-width modulated actuation allows continuously variable adjustment of the camshaft.

The valve opening times are adjusted to the charge changing process depending on engine speed and load.



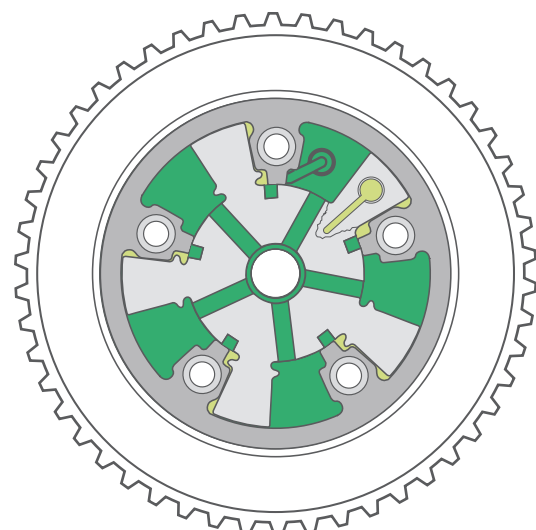
SSP255_023

Inlet camshafts in advance position

The oil pressure enters working area A via the solenoid valve pistons; the rotor moves in the direction of working area B.

The exhaust camshaft is in the retard position (solenoid valve on).

As much overlap as possible results in internal exhaust gas recirculation and optimum torque usage.



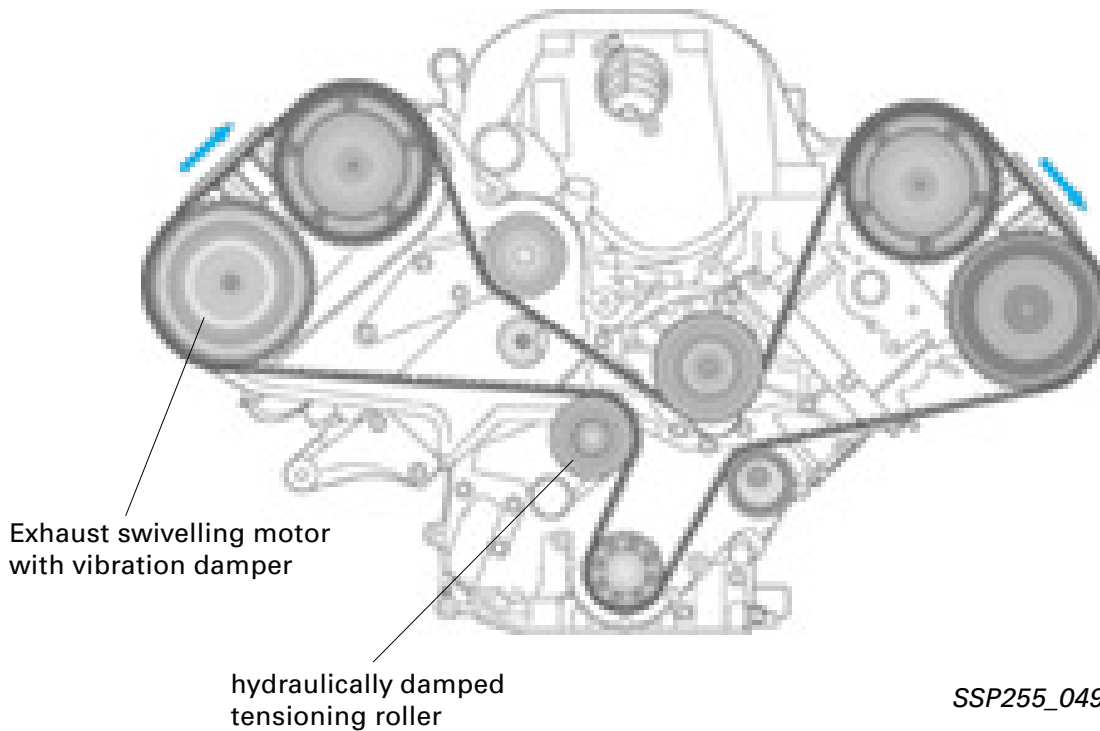
SSP255_024

Engine

Toothed belt drive

Cylinder bank 1

Cylinder bank 2




The drive of the inlet and exhaust camshafts with four camshaft timing controls required a hydraulically damped toothed belt tensioning system.

This was developed in conjunction with a vibration damper on the exhaust camshaft of the right cylinder bank and the latest generation of toothed belt.

The toothed belt is installed using several special tools:

- T40026 Crankshaft clamping bolt
- 3299/1 Clawed tensioning element (ribbed belt)
- T40030 Camshaft setting gauge
- T40028 Camshaft timing control socket insert

 The exhaust swivelling motor of cylinder bank 1 has a damper to compensate for combustion pulses.

Air intake

The previous air filter housing had to be re-designed because of the new headlight housing.

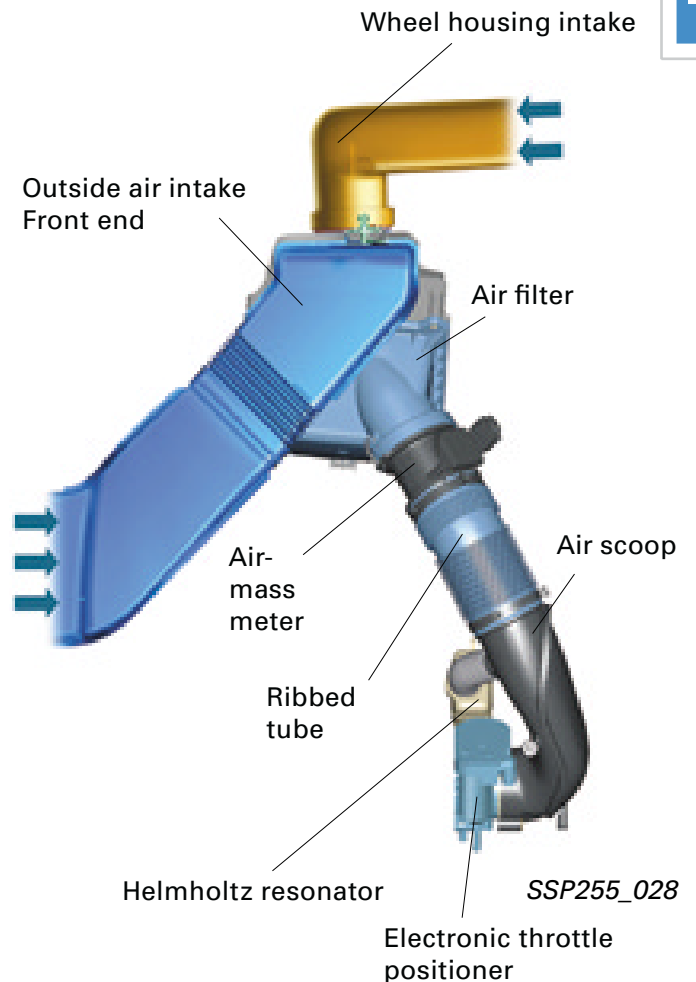
The air filter housing is now narrower with the same air volume as its predecessor, but the air intake has been increased by around 50 %.

Air is taken in through the front end and the wheel housing in order to reduce the intake speed.

The intake noise is damped by a Helmholtz resonator.

This has a volume of 250 cm³ and it opens directly into the most effective part of the air scoop.

This dampens excessive noise at speeds between 4000 and 5000 rpm.



Intake module

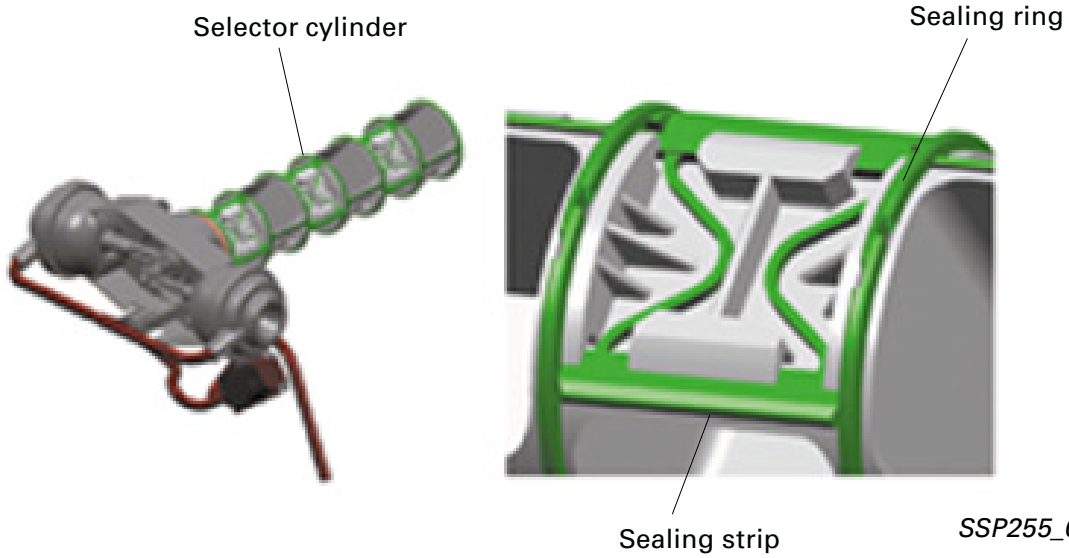
The design provides two intake manifold lengths by means of a selector cylinder.



SSP255_031



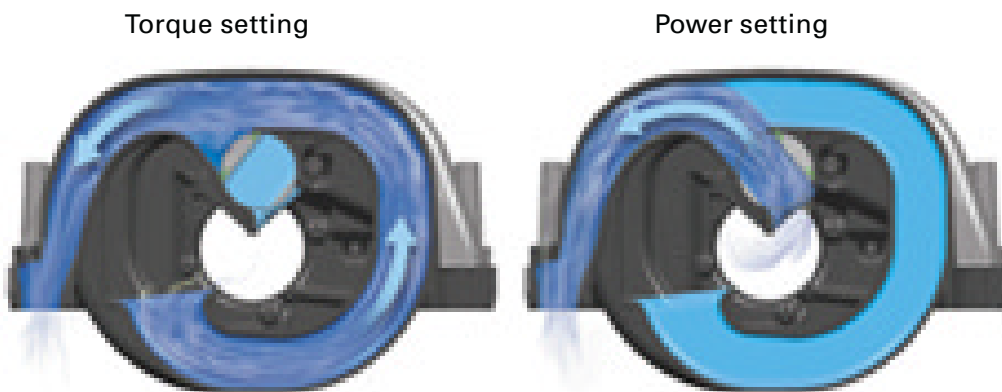
Engine



The selector element is a plastic rotary port running on 2 bearings which is activated by two vacuum units (in order to achieve equal distribution of the load on the cylinder). It is returned to the initial position via a spring.

The spring-loaded connection of the two sealing strips to a sealing element ensures an optimum seal at any load and any tolerance.

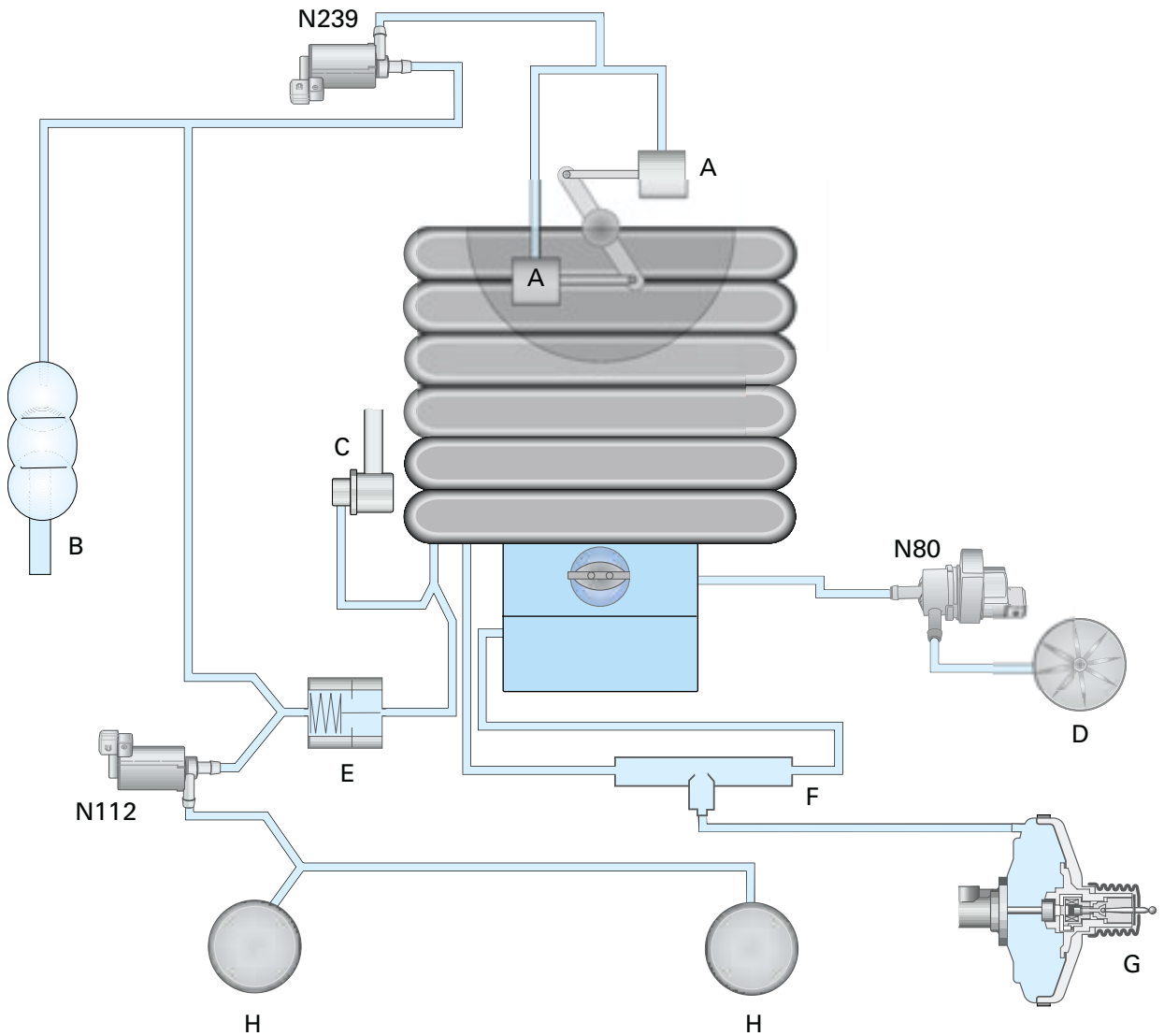
Pre-tensioned sealing rings on the cylinder for each duct provide significantly improved leakage values compared to earlier designs. This contributes to the development of more than 300 Nm of torque.



SSP255_029

The selector cylinder enables 2-stage longitudinal swivel-tube switching. In the torque position, the duct length is 640 mm, in the power position it is 287 mm. The switching point from long to short is at approx. 4200 rpm.

Vacuum system overview

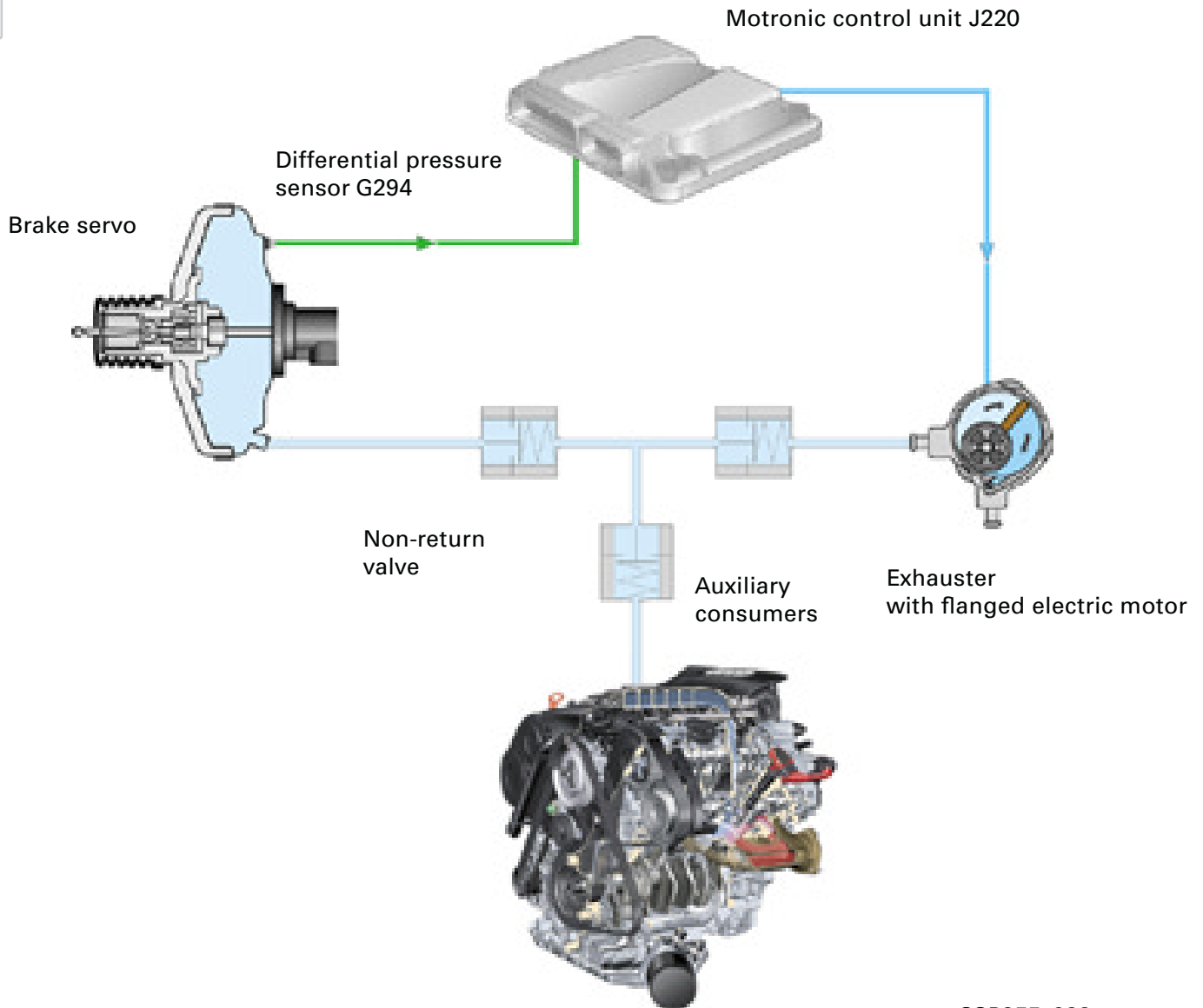


SSP255_032

- | | | | |
|---|--|------|--|
| A | Vacuum units for register intake manifold changeover | F | Suction jet pump |
| B | Vacuum reservoir | G | Brake servo |
| C | Fuel rail with pressure control valve | H | Combi valve for secondary air |
| D | Activated charcoal filter | N80 | Solenoid valve for activated charcoal filter |
| E | Non-return valve | N112 | Secondary air inlet valve |
| | | N239 | Intake manifold flap changeover valve |

Engine

Vacuum system (vehicles with automatic gearbox)



SSP255_033

Constantly increasing load requirements (wider opened throttle valve) in some operating statuses, e. g. when the catalytic converter is warming up while the engine is idling after starting up, result in a reduction of the vacuum generated by the engine.

To avoid losing any braking efficiency, an electric vacuum pump is used to assist braking in vehicles with automatic gearbox.

The relay is activated by the engine control unit when a drop in the vacuum in the brake servo is detected.

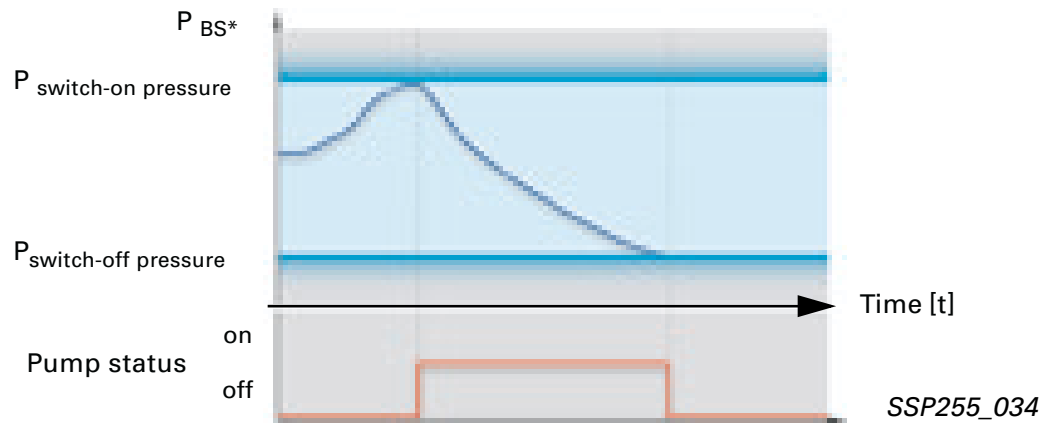
Activation of the vacuum pump

The vacuum pump is activated under the following conditions:

- ▶ $P_{BS^*} > P_{\text{switch-on pressure}}$ approx. 500 mbar

The vacuum pump is deactivated under these conditions:

- ▶ $P_{BS^*} < P_{\text{switch-off pressure}}$ approx. 300 mbar



Altitude correction

The altitude value calculated in the control unit is compared with the pressure of the brake servo sender G294. The electric vacuum pump is activated if there is a relevant difference in pressure.

Self-diagnosis

Final control diagnosis: the vacuum pump should run for approx. 10 seconds.

Measured value block: Channel 08

| Byte 1 | Byte 2 | Byte 3 | Byte 4 |
|---------------------------------------|--------------------|----------------------|-----------------------------|
| Brake actuated/ brake not actuated | Voltage supply (V) | pump on/ pump off | brake servo pressure (mbar) |

*Brake servo



Engine

Exhaust system

An air-gap-insulated manifold in monocoque design has been developed for the 3.0 l engine.

This manifold consists of three separate internal pipes, so-called inliners, for conducting the gas, and a temperature-insulated outer shell.

The inliners, which are manufactured using the IHM (internal high pressure moulding) process owing to their compact geometry, join into a "3 in 1" outlet flange.

This joining of the inliners enables a precise inflow to the primary catalytic converters, allowing the catalytic converter to start up quickly thanks to an optimisation of the pipe geometry and modification of the monolith.

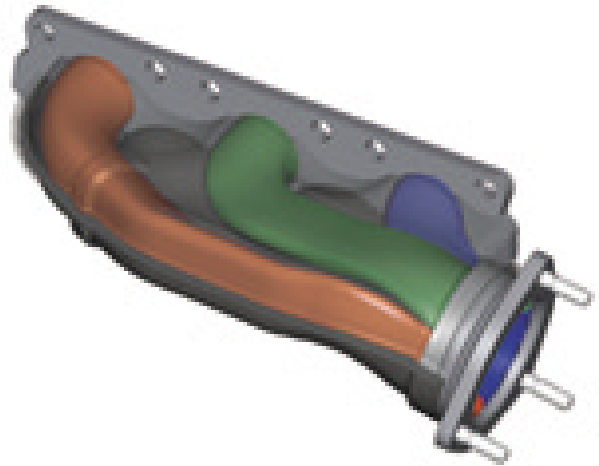
The engine has 2 ceramic primary catalytic converters installed close to the engine with a cell density of 600 cpsi each and a coating of three precious metals.

This achieves a quick start-up of the catalytic converter.

The two main catalytic converters in the underbody area with a cell density of 400 cpsi and coated in three precious metals ensure long-term stability of exhaust emissions at optimum exhaust back pressure.

The three precious metals in the coating are:

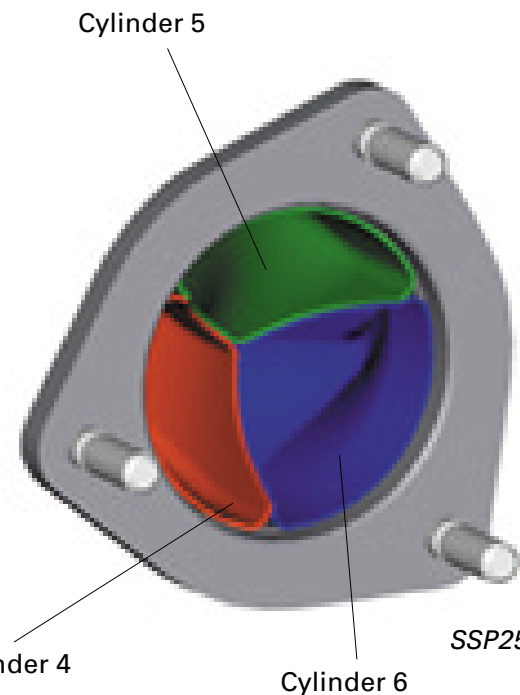
- platinum
- palladium
- rhodium



SSP255_035



For more information on the IHM process, please see SSP 239 – Audi A2, Body.



SSP255_036



cpsi = cells per square inch
600 cpsi = 600 cells per 6.452 cm²

Engine management

The ME 7.1.1 engine control unit is a torque driven electronic throttle system with constant lambda control, two broadband probes upstream of the catalytic converter and two two-point probes downstream of the catalytic converter.

The focus during development was filling-level monitoring and torque co-ordination. Adjusting four camshafts, two of them continuously, demands a considerable amount of computing capacity and speed. In order to achieve this computing performance, the engine control unit has a 32 MHz processor.

It is imperative that both cylinder banks are synchronised.

Because of component tolerances it is possible that the inlet camshaft timing controls perform adjustments at different speeds, especially when the oil is cold or extremely hot.

For this reason, a bank equaliser has been created with four Hall senders for the first time on a two-bank system with a control unit.

Equalisation is performed according to the master-slave principle.

The retarded camshaft timing control on one cylinder bank (master) determines the nominal values for the other cylinder bank (slave). This ensures correct pre-control of the fuel quantity and ignition for dynamic processes under any road conditions.



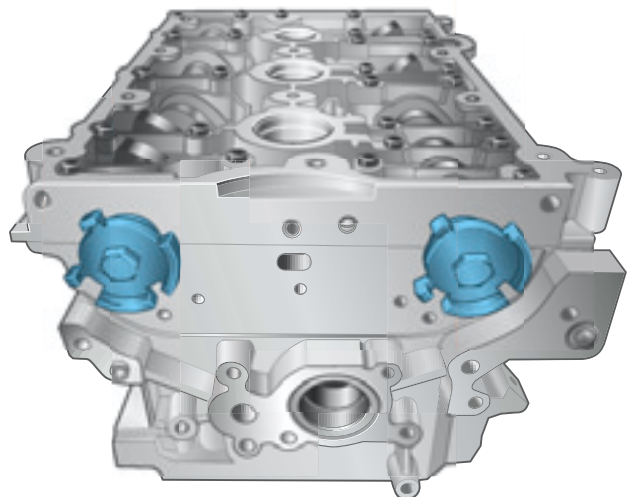
Sensors/Actuators

Phase sensors 1 - 2 - 3 - 4

Four phase sensors are required to monitor the individual positions of the camshafts in relation to the crankshaft.

If one or more sensors fail, the swivelling motors are mechanically locked by the differential pressure pins.

The engine will still start despite loss of signal, permitting emergency running.



SSP255_037

Engine

Overview of system



Sensors

Hot film air mass meter G70

Engine speed sender G28

Hall sender G40
Hall sender 2 G163
Hall sender 3 G300
Hall sender 4 G301

Lambda probe upstream of catalytic converter G39
Lambda probe downstream of catalytic converter G130
Lambda probe 2 G108
Lambda probe 2 downstream of catalytic converter G131

Throttle valve control unit J338 with throttle valve drive G186 (electronic throttle control)
Angle sender 1 for throttle valve drive G187
Angle sender 2 for throttle valve drive G188

Coolant temperature sender G2 and G62

Knock sensor 1 G61 (Bank 1) and
Knock sensor 2 G66 (Bank 2)

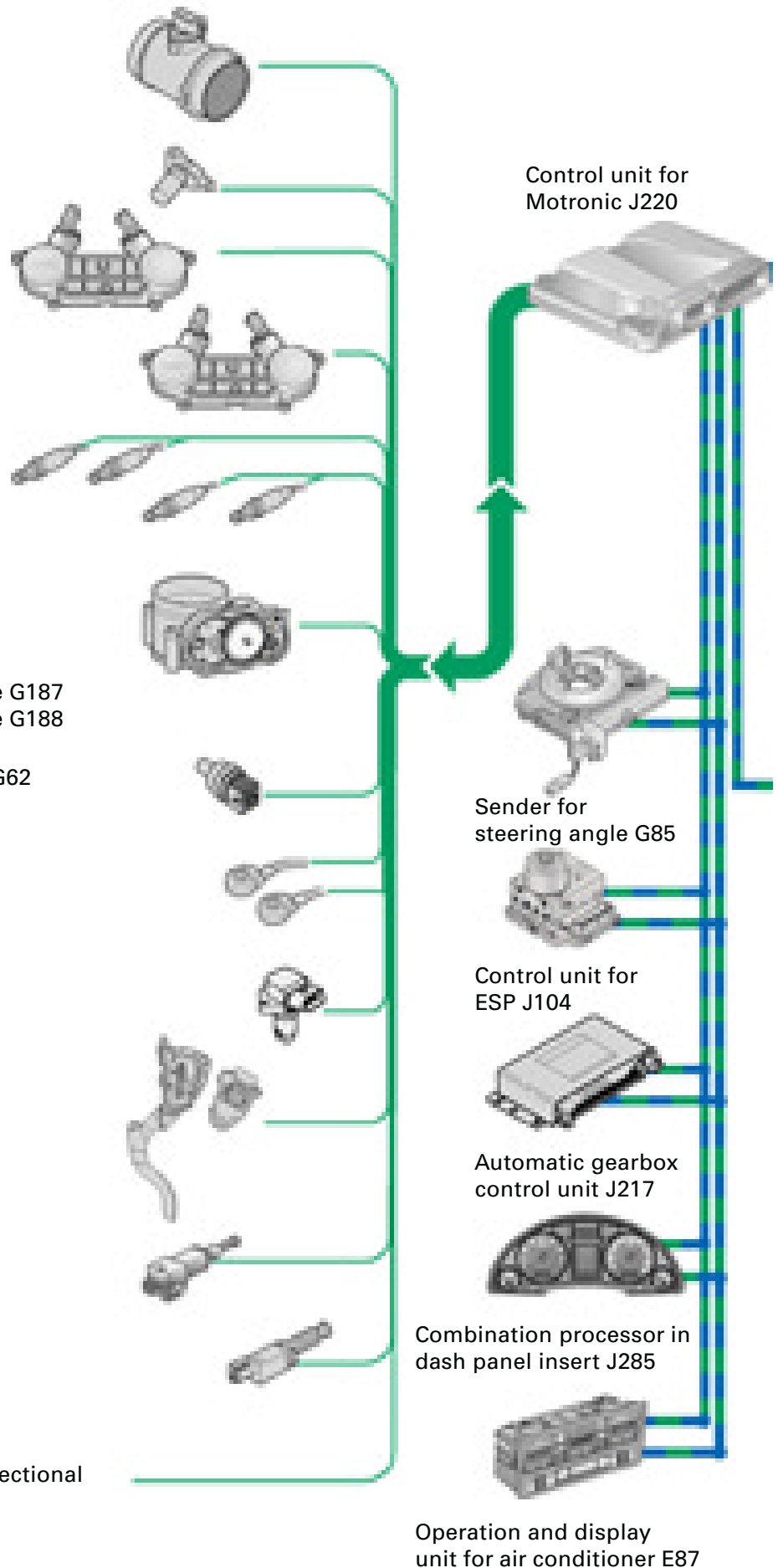
Pressure sensor for brake servo G294

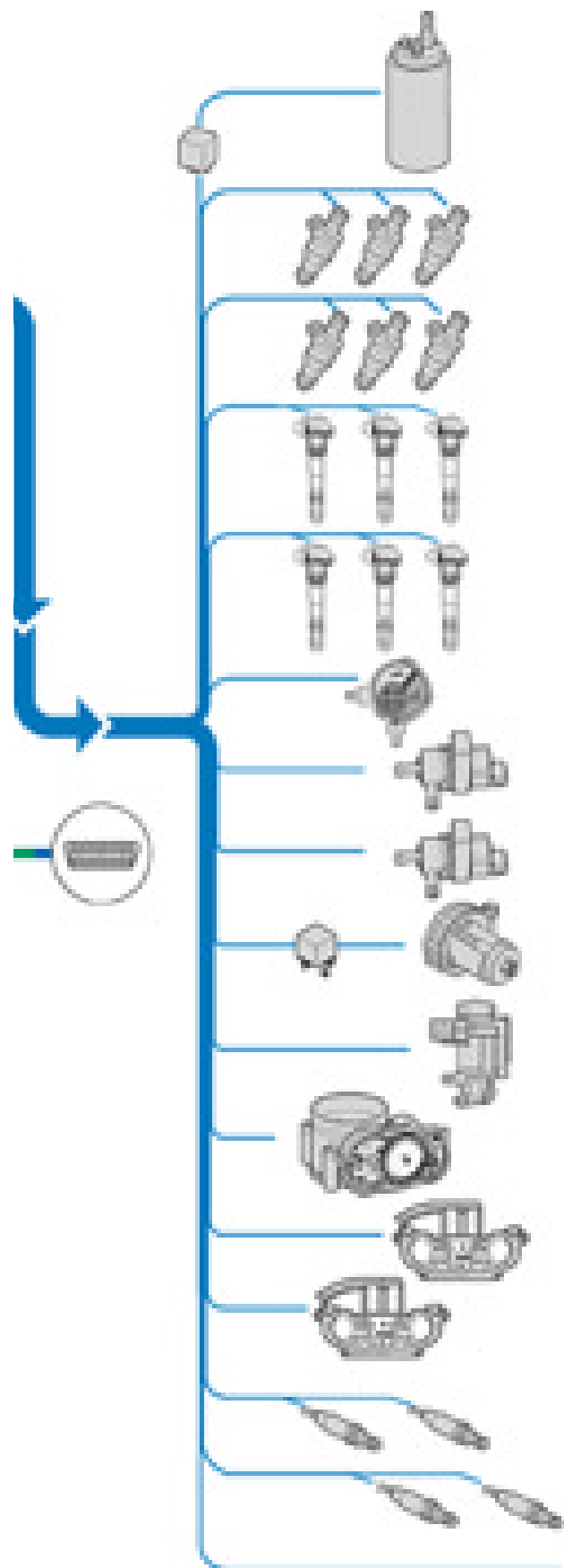
Pedal value sender/accelerator pedal module with accelerator position sender (1) G79 and accelerator position sender (2) G185

Brake light switch F and brake pedal switch F47

Clutch pedal switch F36

Auxiliary signals
– Air conditioner ready
– air conditioning compressor bi-directional
– Crash signal
– CCS switch





Actuators

Fuel pump relay J17 and fuel pump G6

Injectors N30, N31, N32

Injectors N33, N83, N84

Ignition coils N (Cyl. 1), N128 (Cyl. 2), N158 (Cyl. 3.)

Ignition coils N163 (Cyl. 4), N164 (Cyl. 5), N189 (Cyl. 6.)

Vacuum pump with electric motor

Solenoid valve for activated charcoal filter N80

Intake manifold flap changeover valve N239

Secondary air pump relay J299 and secondary air pump motor V101

Secondary air inlet valve N112

Throttle valve control unit J338 with throttle valve drive G186 (electronic throttle control)

Valve for camshaft adjustment N205 (Bank 1) and N208 (Bank 2)

Control unit for Lambda probe heater J208

Heater for lambda probe Z19 (Bank 1)

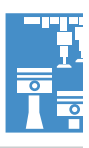
Heater for lambda probe Z28 (Bank 2)

Heater for lambda probe 1, downstream of catalytic converter Z29

Heater for lambda probe 2, downstream of catalytic converter Z30

Auxiliary signals

– Air conditioning compressor









Engine



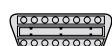
Functional diagram for the 3.0 I-5V

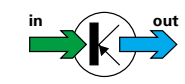
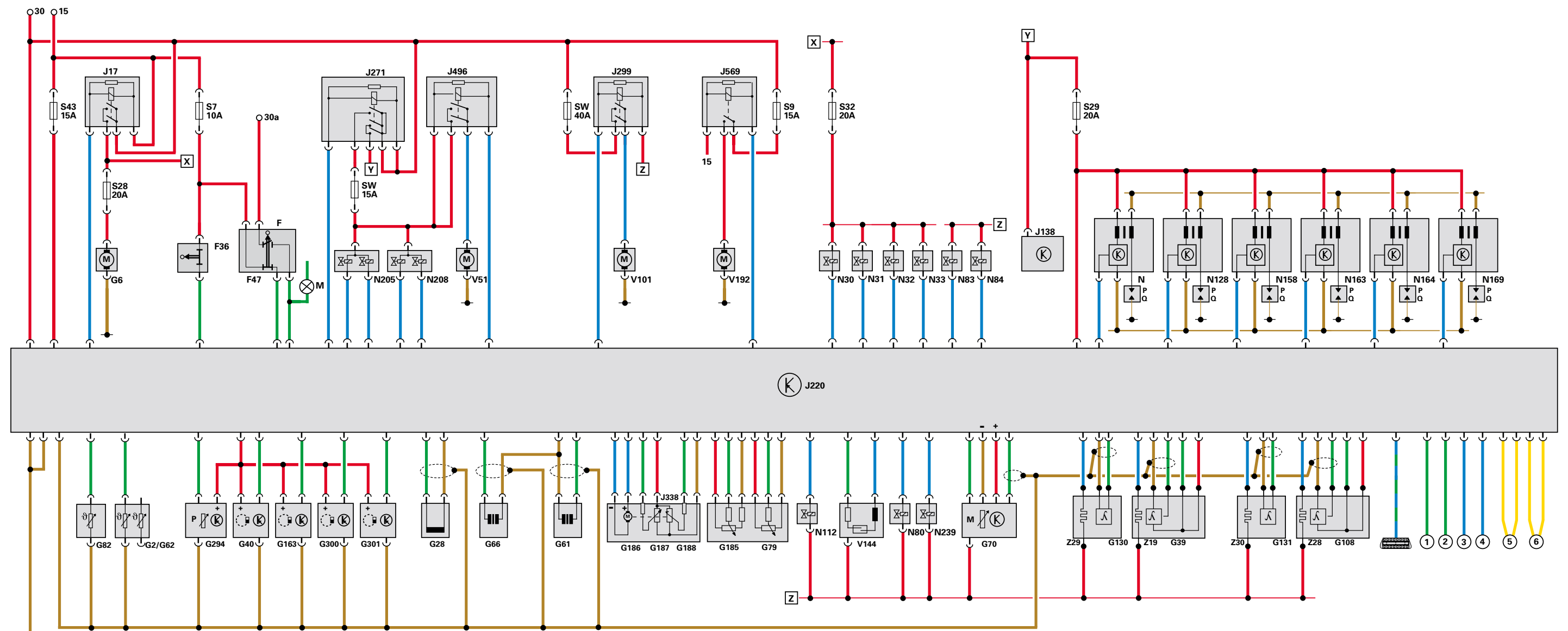
| | | | |
|------|---|------|--|
| F | Brake light switch | N158 | Ignition coil 3 |
| F36 | Clutch pedal switch | N163 | Ignition coil 4 |
| F47 | Brake pedal switch for cruise control system | N164 | Ignition coil 5 |
| G2 | Coolant temperature sender | N189 | Ignition coil 6 |
| G6 | Fuel pump | N205 | Valve 1 for camshaft adjustment |
| G28 | Engine speed sender | N208 | Valve 2 for camshaft adjustment |
| G39 | Lambda probe | N239 | Intake manifold flap changeover valve |
| G40 | Hall sender | S | Fuses |
| G61 | Knock sensor 1 | V51 | Pump for coolant run-on |
| G62 | Coolant temperature sender | V101 | Motor for secondary air pump |
| G66 | Knock sensor 2 | V144 | Diagnosis pump for fuel system |
| G70 | Air mass meter | V192 | Vacuum pump for brake |
| G79 | Accelerator position sender | Z19 | Heater for lambda probe |
| G82 | Coolant temperature sender for engine outlet | Z28 | Heater for lambda probe 2 |
| G108 | Lambda probe 2 | Z29 | Heater for lambda probe 1, downstream of catalytic converter |
| G130 | Lambda probe downstream of catalytic converter | Z30 | Heater for lambda probe 2, downstream of catalytic converter |
| G131 | Lambda probe 2 downstream of catalytic converter | | |
| G163 | Hall sender 2 | | |
| G185 | Accelerator position sender 2 | | |
| G186 | Throttle valve drive (electronic throttle control) | | |
| G187 | Angle sender 1 for throttle valve drive (electronic throttle control) | | |
| G188 | Angle sender 2 for throttle valve drive (electronic throttle control) | | |
| G294 | Pressure sensor for brake servo | | |
| G300 | Hall sender 3 | | |
| G301 | Hall sender 4 | | |
| J17 | Fuel pump relay | | |
| J138 | Control unit for radiator fan run-on | | |
| J220 | Control unit for Motronic | | |
| J271 | Power supply relay for Motronic | | |
| J299 | Secondary air pump relay | | |
| J496 | Auxiliary coolant pump relay | | |
| J569 | Brake servo relay | | |
| M | Lamps | | |
| N | Ignition coil | | |
| N30 | Injector, cylinder 1 | | |
| N31 | Injector, cylinder 2 | | |
| N32 | Injector, cylinder 3 | | |
| N33 | Injector, cylinder 4 | | |
| N80 | Solenoid valve 1 for activated charcoal filter system | | |
| N83 | Injector, cylinder 5 | | |
| N84 | Injector, cylinder 6 | | |
| N112 | Secondary air inlet valve | | |
| N128 | Ignition coil 2 | | |

Colour coding

| | |
|---|-------------------------|
|  | = Input signal |
|  | = Output signal |
|  | = Positive power supply |
|  | = Earth |
|  | = CAN BUS |
|  | = Bi-directional |

Auxiliary signals

| | |
|---|--|
|  | K diagnostic connection |
| ① | DF signal |
| ② | Crash signal |
| ③ | PWM signal to radiator fan |
| ④ | TD signal (V30 automatic gearbox only) |
| ⑤ | Databus drive |
| ⑥ | Databus information |
| X | } Connection within the functional diagram |
| Y | |
| Z | |



Notes

| |
|--|
| |
| |
| |
| |

Notes

All rights reserved,
including the right to
make technical changes.
AUDI AG
Dept. I/VK-5
D-85045 Ingolstadt
Fax 0841/89-36367
040.2810.74.20
Technical status 03/01
Printed in Germany